



Operation and Maintenance Instructions

FOR EVAPCO INDUCED DRAFT AND FORCED DRAFT CLOSED CIRCUIT COOLERS AND EVAPORATIVE CONDENSERS



ATC-E/eco-ATC/
ATWB/eco-ATW



eco-ATWB-E



eco-ATWB-H



PMC-E/eco-PMC
PMCQ/PMWQ



ESWA/ESWB



eco-LSWE
LSWE/LSC-E



eco-LRWB
LRWB/LRC



MTW/MTC

For EVAPCO Authorized Parts and Service, Contact Your Local EVAPCO Representative or the Local Mr. GoodTower® Service Provider

EVAPCO, Inc. — World Headquarters & Research/Development Center

EVAPCO, Inc. • P.O. Box 1300 • Westminster, MD 21158 USA
PHONE: 410-756-2600 • FAX: 410-756-6450 • E-MAIL: marketing@evapco.com

EVAPCO North America

EVAPCO, Inc. World Headquarters

P.O. Box 1300
Westminster, MD 21158 USA
Phone: 410-756-2600
Fax: 410-756-6450
E-mail: marketing@evapco.com

EVAPCO East
5151 Allendale Lane
Taneytown, MD 21787 USA
Phone: 410-756-2600
Fax: 410-756-6450
E-mail: marketing@evapco.com

EVAPCO Midwest
1723 York Road
Greenup, IL 62428 USA
Phone: 217-923-3431
Fax: 217-923-3300
E-mail: evapcomw@evapcomw.com

EVAPCO West
1900 West Almond Avenue
Madera, CA 93637 USA
Phone: 559-673-2207
Fax: 559-673-2378
E-mail: contact@evapcowest.com

EVAPCO Iowa
925 Quality Drive
Lake View, IA 51450 USA
Phone: 712-657-3223
Fax: 712-657-3226

**EVAPCO Iowa
Sales & Engineering**
215 1st Street, NE
P.O. Box 88
Medford, MN 55049 USA
Phone: 507-446-8005
Fax: 507-446-8239
E-mail: evapcomn@evapcomn.com

EVAPCO Newton
701 East Jourdan Street
Newton, IL 62448 USA
Phone: 618-783-3433
Fax: 618-783-3499
E-mail: evapcomw@evapcomw.com

EVAPCOLD Manufacturing
521 Evapco Drive
Greenup, IL 62428 USA
Phone: 217-923-3431
E-mail: evapcomw@evapcomw.com

EVAPCO-BLCT Dry Cooling, Inc.
1011 US Highway 22 West
Bridgewater, New Jersey 08807 USA
Phone: 1-908-379-2665
E-mail: info@evapco-blct.com

**Refrigeration Valves &
Systems Corporation**
A wholly owned subsidiary of EVAPCO, Inc.
1520 Crosswind Dr.
Bryan, TX 77808 USA
Phone: 979-778-0095
Fax: 979-778-0030
E-mail: rvs@rvscorp.com

EVAPCO Northwest
5775 S.W. Jean Road, Suite 210
Lake Oswego, Oregon 97035 USA
Phone: 503-639-2137
Fax: 503-639-1800

EvapTech, Inc.
A wholly owned subsidiary of EVAPCO, Inc.
8331 Nieman Road
Lenexa, KS 66214 USA
Phone: 913-322-5165
Fax: 913-322-5166
E-mail: marketing@evaptech.com

Tower Components, Inc.
A wholly owned subsidiary of EVAPCO, Inc.
5960 US HWY 64E
Ramseur, NC 27316
Phone: 336-824-2102
Fax: 336-824-2190
E-mail: mail@towercomponentsinc.com

EVAPCO South America

EVAPCO Brasil
Equipamentos Industriais Ltda.
Rua Alexandre Dumas, 1601
Conj. 13, 14, 14 – Edifício Stelvio Mazza
04717-004 São Paulo - Brasil
Phone: (55) 19-5681-2000

EVAPCO Europe

**EVAPCO Europe BVBA
European Headquarters**
Industrieterrein Oost 4010
3700 Tongeren, Belgium
Phone: (32) 12-395029
Fax: (32) 12-238527
E-mail: evapco.europe@evapco.be

EVAPCO Europe, S.r.l.
Via Ciro Menotti 10
I-20017 Passirana di Rho
Milan, Italy
Phone: (39) 02-939-9041
Fax: (39) 02-935-00840
E-mail: evapcoeuropa@evapco.it

EVAPCO Europe, S.r.l.
Via Dosso 2
23020 Piateda Sondrio, Italy

EVAPCO Europe GmbH
Meerbuscher Straße 64-78
Haus 5
40670 Meerbusch, Germany
Phone: (49) 2159-69560
Fax: (49) 2159-695611
E-mail: info@evapco.de

Flex coil a/s
A wholly owned subsidiary of EVAPCO, Inc.
Knegårdvej 115
DK-9440 Aabybro Denmark
Phone: (45) 9824 4999
Fax: (45) 9824 4990
E-mail: info@flexcoil.dk

EVAPCO S.A. (Pty.) Ltd.
A licensed manufacturer of EVAPCO, Inc.
18 Quality Road
Isando 1600
Republic of South Africa
Phone: (27) 11-392-6630
Fax: (27) 11-392-6615
E-mail: evapco@evapco.co.za

Evap Egypt Engineering Industries Co.
A licensed manufacturer of EVAPCO, Inc.
5 El Nasr Road
Nasr City, Cairo, Egypt
Phone: 2 02 24022866/2 02 24044997
Fax: 2 02 24044667/2 02 24044668
E-mail: Primacool@link.net / Shady@primacool.net

EVAPCO Asia/Pacific

EVAPCO Asia/Pacific Headquarters
1159 Luoning Rd. Baoshan Industrial Zone
Shanghai, P. R. China, Postal Code: 200949
Phone: (86) 21-6687-7786
Fax: (86) 21-6687-7008
E-mail: marketing@evapcochina.com

**EVAPCO (Shanghai) Refrigeration
Equipment Co., Ltd.**
1159 Luoning Rd., Baoshan Industrial Zone
Shanghai, P.R. China, Postal Code: 200949
Phone: (86) 21-6687-7786
Fax: (86) 21-6687-7008
E-mail: marketing@evapcochina.com

**Beijing EVAPCO Refrigeration
Equipment Co., Ltd.**
No. 6 the 4th Block
Yanxi Economic Development Zone
Huairou District
Beijing, P.R. China, Postal Code: 101407
Phone: (86) 10 6166-7238
Fax: (86) 10 6166-7395
E-mail: evapcobj@evapcochina.com

EVAPCO Australia (Pty.) Ltd.
34-42 Melbourne Road
P.O. Box 436
Riverstone, N.S.W. Australia 2765
Phone: (61) 2 9627-3322
Fax: (61) 2 9627-1715
E-mail: sales@evapco.com.au

EVAPCO Composites Sdn. Bhd
No. 70 (Lot 1289) Jalan Industri 2/3
Rawang Integrated Industrial Park
Rawang, Selangor, 48000 Malaysia
Phone: 60 3 6092-2209
Fax: 60 3 6092-2210

EvapTech Asia Pacific Sdn. Bhd
A wholly owned subsidiary of EvapTech, Inc.
B-6-1, IOI Boulevard
Jalan Kenari 5, Bandar Puchong Jaya
47170 Puchong, Selangor Darul Ehsan
Malaysia
Phone: (60-3) 8070-7255
Fax: (60-3) 8070-5731
E-mail: marketing-ap@evaptech.com

EVAPCO...SPECIALISTS IN HEAT TRANSFER PRODUCTS AND SERVICES.

Visit EVAPCO's Website at: <http://www.evapco.com>



Table of Contents

Introduction4
Safety Precautions4
Terminology4
Initial Storage and/or Idle Period Recommendations5
International Building Code Provision6
Initial and Seasonal Start-Up Checklist6
General6
Initial and Seasonal Start-Up6
Maintenance Checklist8
Seasonal Shut-Down Checklist10
Basic Closed Circuit Cooler/Condenser Sequence of Operation10
Fan System11
Fan Motor Bearings11
Fan Shaft Ball Bearings11
Fan Shaft Sleeve Bearings – (4' wide LS units only)12
Fan Belt Adjustment12
Gear Drives14
eco-W/WE14
Air Inlet14
Fan System – Capacity Control14
Fan Motor Cycling14
Sequence of Operation for Fan Motor Cycling14
Two-Speed Motors14
Sequence of Operation for Two Fan Units with Two Speed Motors during Peak Load15
Variable Frequency Drives15
Sequence of Operations / Guidelines for Multi-fan Units with a VFD during Peak Load15
eco-WE15
Recirculated Water System – Routine Maintenance16
Suction Strainer in Cold Water Basin16
Cold Water Basin16
Operating Level of Water in Cold Water Basin16
Water Make Up Valve17
Pressurized Water Distribution Systems18
Bleed-Off Valve19
Pump (When Supplied)19
Water Treatment and Water Chemistry20
Bleed or Blowdown20
Galvanized Steel – Passivation20
Water Chemistry Parameters21
Control of Biological Contamination21
Gray Water and Reclaimed Water22
Air Contamination22
Cold Weather Operation22
Unit Layout22
Freeze Protection of Recirculating Water22
Freeze Protection of Closed Circuit Cooler Coils24
Unit Accessories25
Cold Water Basin Heaters25
Remote Sumps25



Electric Water Level Control25
Vibration Cut Out Switches25
Capacity Control Methods for Cold Weather Operation25
Induced Draft Unit Capacity Control25
Forced Draft Unit Capacity Control26
Ice Management26
Induced Draft Units26
Forced Draft Units27
Troubleshooting27
Replacement Parts30
Part Identification Drawings31
ATWB/eco-ATW 3' Wide Units31
ATWB/eco-ATW 4'x4' & 4'x6' Wide Units32
ATC/ATWB/eco-ATW 4'x9' & 4'x12' Wide Units33
ATC-E/ATWB/eco-ATC/eco-ATW 8' & 8.5' Wide Units34
ATC-E/ATWB/eco-ATC/eco-ATW 10' & 12' Wide Units35
eco-ATWE 8.5' Wide Units36
eco-ATWE 10' Wide Units37
eco-ATWE 12' Wide Units38
MTW & MTC 4' Wide Units (4' x 6' & 4' x 9')39
MTW & MTC 8' Wide Units40
MTW & MTC 10' Wide Units41
MTW & MTC 12' Wide Units42
ESWA 8.5' Wide Units43
ESWA 12' Wide Units44
ESWA 14' Wide Units45
LSC-E/LSWE/eco-LSWE 4' Wide Units48
LSC-E/LSWE/eco-LSWE 5' Wide Units49
LSC-E/LSWE/eco-LSWE 8' Wide Units (Single Side Fans)50
LSC-E/LSWE/eco-LSWE 10' Wide Units51
LRC/LRWB 3' Wide Units52
LRC/LRWB 5' Wide Units53
LRC/LRWB 8' Wide Units54
PMC-E 5' Wide Units55
PMC-E/PMWQ 10' and 12' Wide Units56
Notes57-59



Introduction

Congratulations on the purchase of your EVAPCO evaporative cooling unit. EVAPCO equipment is constructed of the highest quality materials and designed to provide years of reliable service when properly maintained.

Evaporative cooling equipment is often remotely located and periodic maintenance checks are often overlooked. It is important to establish a regular maintenance program and be sure that the program is followed. This bulletin should be used as a guide to establish a program. A clean and properly serviced unit will provide a long service life and operate at peak efficiency.

This bulletin includes recommended maintenance services for unit start up, unit operation and unit shutdown and the frequency of each. Please note: the recommendations of frequency of service are minimums. Services should be performed more often when operating conditions necessitate.

Become familiar with your evaporative cooling equipment. Refer to the isometric drawings located on pages 31-52 for information on the arrangement of components in your equipment.

If you should require any additional information about the operation or maintenance of this equipment, contact your local EVAPCO representative. You may also visit www.evapco.com or www.mrgoodtower.com for more information.

Safety Precautions

Qualified personnel should use proper care, procedures and tools when operating, maintaining or repairing this equipment in order to prevent personal injury and/or property damage. The warnings listed below are to be used as guidelines only.

WARNING: This equipment should never be operated without fan screens and access doors properly secured and in place.

WARNING: A lockable disconnect switch should be located within sight of the unit for each fan motor associated with this equipment. Before performing any type of service or inspection of the unit make certain that all power has been disconnected and locked in the "OFF" position.

WARNING: The top horizontal surface of any unit is not intended to be used as a working platform. No routine service work is required from this area.

WARNING: The recirculating water system may contain chemicals or biological contaminants including Legionella Pneumophila, which could be harmful if inhaled or ingested. Direct exposure to the discharge airstream and the associated drift generated during operation of the water distribution system and/or fans, or mists generated while cleaning components of the water system require respiratory protection equipment approved for such use by governmental occupational safety and health authorities.

Terminology

Throughout this manual, the terms "Induced Draft" and "Forced Draft" are used. Below is a list of EVAPCO Closed Circuit Cooler and Condenser products offerings and associated terminology.

Induced Draft equipment includes the following Evapco Product Models:

■ **ES Product Lines**

- ESWA - Closed Circuit Cooler
- ESWB - Closed Circuit Cooler

■ **AT Product Lines**

- ATWB - Closed Circuit Cooler
- ATC-E - Evaporative Condenser

■ MT Product Lines

- MTW - Closed Circuit Cooler
- MTC - Evaporative Condenser

■ Containerized Product Lines

- CATWB - Closed Circuit Cooler
- CATC - Evaporative Condenser

■ eco Product Line

- eco-ATW - Closed Circuit Cooler
- eco-ATWE - Wet/Dry Closed Circuit Cooler
- eco-ATWB-H - Wet/Dry Closed Circuit Cooler
- eco-ATC - Wet/Dry Evaporative Condenser

Forced Draft equipment includes the following Evapco Product Models:

■ LR Product Lines

- LRWB - Closed Circuit Cooler
- LRC - Evaporative Condenser

■ LS Product Lines

- LSWE - Closed Circuit Cooler
- LSC-E - Evaporative Condenser

■ PM Product lines

- PMC-E - Evaporative Condenser
- PMC-EQ - Evaporative Condenser
- PMWQ - Closed Circuit Cooler

Initial Storage and/or Idle Period Recommendations

If the unit will sit for idle periods of time it is recommended that the following be performed in addition to all component manufacturers recommended maintenance instructions.

- The fan/motor/pump bearings and motor bearings need to be turned by hand at least once a month. This can be accomplished by tagging and locking out the unit's disconnect, grasping the fan assembly (or removing the pump motor fan guard), and rotating it several turns.
- If unit sits longer than a few weeks, run gear reducer (if equipped) for 5 minutes weekly.
- If unit sits longer than 3 weeks, completely fill gear reducer with oil. Drain to normal level prior to running.
- If unit sits longer than one month, insulation test motor windings semi-annually.
- If fan motor sits idle for at least 24 hours while the spray pumps are energized distributing water over the coil, motor space heaters (if equipped) should be energized. Alternatively, fan motors may be energized for 10 minutes, twice daily, to drive any moisture condensation out of the motor windings.

International Building Code Provisions

The International Building Code (IBC) is a comprehensive set of regulations addressing the structural design and installation requirements for building systems – including HVAC and industrial refrigeration equipment. The code provisions require that evaporative cooling equipment and all other components permanently installed on a structure must meet the same seismic design criteria as the building.

All items attached to Evapco Closed Circuit Coolers or Evaporative Condensers must be independently reviewed and isolated to meet applicable wind and seismic loads. This includes piping, ductwork, conduit, and electrical connections. These items must be flexibly attached to the Evapco unit so as not to transmit additional loads to the equipment as a result of seismic or wind forces.

Initial and Seasonal Start-Up Checklist

General

1. Verify that the overall installation reflects the requirements of the installation guidelines found in EVAPCO Bulletin 311 – Equipment Layout Manual available at www.evapco.com.
2. For multi-speed fan motors, verify that 30 second or greater time delays are provided for speed changes when switching from high to low speed. Also check to see if interlocks are provided to prevent simultaneously energizing high and low speed, and confirm both speeds operate in the same direction.
3. Verify all safety interlocks work properly.
4. For units operating with a variable frequency drive, make certain that minimum speed requirements have been set. Check with VFD manufacturer for recommended minimum speeds. Check with VFD manufacturer for recommendations on locking out resonance frequencies. See “Fan System Capacity Control” section for more information.
5. Verify that a water treatment plan has been implemented including passivation of galvanized steel units. See “Water Treatment” section for more details.
6. If the unit is going to sit idle for an extended period of time, follow all manufacturers’ fan motor and pump instructions for long term storage. Plastic sheets or tarps should never be used to protect a unit during storage. This practice can trap heat inside the unit, and could potentially cause damage to plastic components. See your local EVAPCO representative for additional information on unit storage.
7. For units subject to freezing climates, high humidity climates, or idle periods lasting 24 hours or more, motor space heaters are suggested and (if equipped) should be energized. Alternatively, fan motors may be energized for 10 minutes, twice daily, to drive any moisture condensation out of the motor windings.

**BEFORE BEGINNING ANY MAINTENANCE, BE CERTAIN THAT THE POWER IS TURNED OFF
AND THE UNIT IS PROPERLY LOCKED AND TAGGED OUT!**

Initial and Seasonal Start-Up

1. Clean and remove any debris, such as leaves and dirt from the air inlets.
2. Flush the cold water basin (with the strainer screens in place) to remove any sediment or dirt.
3. Remove the strainer screen, clean **and reinstall**.
4. Check mechanical float valve to see if it operates freely.
5. Inspect water distribution system nozzles and clean as required. Check for proper orientation.
(This is not required at initial start-up. The nozzles are clean and set at the factory).
6. Check to ensure drift eliminators are securely in place and in the proper orientation.
7. Adjust fan belt tension as required. See “Fan Belt Adjustment” section.
8. Lubricate fan shaft bearings prior to seasonal start-up.
9. Turn the fan(s) and pumps by hand to insure it turns freely without obstructions.

10. Visually inspect the fan blades. Blade clearance should be approximately 3/8" (1/4" minimum) from tip of blade to the fan cowl. The fan blades should be securely tightened to the fan hub.
11. If any stagnant water remains in the system including "dead legs" in the piping, the unit must be disinfected prior to the fans being energized. Please refer to ASHRAE Guideline 12-2000 and CTI Guideline WTP-148 for more information.
12. Manually fill the cold water basin up to the overflow connection.
13. For closed circuit coolers, fill the heat exchanger coil with the specified fluid and "burp" air from the system before pressurizing, using vents on coil inlets. Do not do this for evaporative condensers.

For eco-WE & eco-W with optional controls, see controls O&M for proper start up procedure.

After the unit has been energized, check the following:

1. Adjust mechanical float valve as required to the proper water level.
2. Unit basin should be filled to the proper operating level. See "Recirculating Water System Operating Levels" section for more details.
3. Verify fan is rotating in proper direction.
4. Start the spray water pump and check for proper rotation as indicated by the arrow on the front cover.
5. Measure voltage and current on all three power leads of pump and fan motor. The current should not exceed the motor nameplate full load amp rating taking the service factor into account.
6. Adjust bleed valve to proper flow rate. Maximum bleed off is 3 US GPM per 100 tons. Consult your qualified water treatment person to fine tune the minimum bleed necessary.
7. See fan and pump motor manufacturer maintenance and long term storage instructions for more detailed information. The motors should be lubricated and serviced in accordance with manufacturer's instructions.
8. All new evaporative cooling equipment and associated piping should be pre-cleaned and flushed to remove grease, oil, dirt, debris and other suspended solids prior to operation. Any pre-cleaning chemistry should be compatible with the cooling equipment's materials of construction. Alkaline formulations should be avoided for systems which include galvanized materials of construction.

Closed hydronic systems connected to either a closed-circuit cooler or dry cooler should be pre-cleaned and flushed to remove debris, grease, flash rust, oil, and other suspended solids prior to operation. Evapco recommends the use of inhibitor chemistry or inhibited glycol to minimize corrosion and scale during normal operation.



MAINTENANCE CHECKLIST



PROCEDURE	JAN	FEB	MAR	APR	MAY	JUN	JUL	AUG	SEP	OCT	NOV	DEC
1. Clean pan strainer – monthly or as needed												
2. Clean and flush pan* – quarterly or as needed												
3. Check bleed-off valve to make sure it is operative – monthly												
4. Lubricate pump and pump motor according to manufacturer's instructions												
5. Check operating level in pan and adjust float valve if necessary – monthly												
6. Check water distribution system and spray pattern – monthly												
7. Check drift eliminators – quarterly												
8. Check the fan blades for cracks, missing balancing weights, and vibrations – quarterly												
9. Lubricate fan shaft bearings – every 1000 hours of operation or every three months												
10. Lubricate fan motor bearings – see mfg's instructions. Typically for non-sealed bearings, every 2-3 years												
11. Check belt tension and adjust – monthly												
12. Inspect and grease sliding motor base – annually or as needed												
13. Check fan screens, inlet louvers, fans and dry cooler coil (eco-ATC, eco-ATW, eco-ATWE). Remove any dirt or debris – monthly												
14. Inspect and clean protective finish – annually - Galvanized: scrape and coat with ZRC - Stainless: clean and polish with a stainless steel cleaner.												
15. Check water quality for biological contamination. Clean unit as needed and contact a water treatment company for recommended water treatment program* – regularly												

OPTIONAL ACCESSORIES:

1. Gear Reducer – Check oil level with unit stopped – 24 hours after start-up & monthly												
2. Gear Reducer/Piping – Do visual inspection for oil leaks, auditory inspection for unusual noises and vibrations – monthly												
3. Gear Reducer – Replace oil – semi-annually												
4. Oil Pump – Do visual inspection for leaks and proper wiring – monthly												
5. Gear Reducer/Coupling – Check alignment of the system – 24 hours after start-up & monthly												

* Evaporative cooling equipment must be cleaned on a regular basis to prevent the growth of bacteria including Legionella Pneumophila.



MAINTENANCE CHECKLIST



OPTIONAL ACCESSORIES:	JAN	FEB	MAR	APR	MAY	JUN	JUL	AUG	SEP	OCT	NOV	DEC
6. Coupling/Shaft – Inspect flex elements and hardware for tightness, proper torque & crack/deterioration – monthly												
7. Heater Controller – Inspect controller and clean probe ends – quarterly												
8. Heater – Inspect junction box for loose wiring and moisture – one month after start-up and semi-annually												
9. Heater – Inspect elements for scale build-up – quarterly												
10. Electronic Water Level Controller – Inspect junction box for loose wiring and moisture – semi-annually												
11. Electronic Water Level Controller – Clean probe ends of scale build-up – quarterly												
12. Electronic Water Level Controller – Clean inside the standpipe – annually												
13. Solenoid Make-up Valve – Inspect and clean valve of debris – as needed												
14. Vibration Switch (mechanical) – Inspect enclosure for loose wiring and moisture – one month after start-up and monthly												
15. Vibration Switch – Adjust the sensitivity – during start-up and annually												
16. Sump Sweeper Piping – Inspect and clean piping of debris – semi-annually												
17. Water Level Indicator – Inspect and clean – annually												

DURING IDLE PERIODS:

1. Two or more Days: Energize motor space heaters or run motors for 10 minutes twice daily												
2. Few Weeks: Run gear reducer for 5 minutes – weekly												
3. Several Weeks: Completely fill gear reducer with oil. Drain to normal level prior to running.												
4. One Month or longer: Rotate motor shaft/fan 10 turns – bi-weekly												
5. One Month or longer: Megger test motor windings – semi-annually												

Seasonal Shut-Down Checklist

When the system is to be shut down for an extended period of time, the following services should be performed.

1. The evaporative cooling unit cold water basin should be drained
2. The cold water basin should be flushed and cleaned with the suction strainer screens in place.
3. The suction strainer screens should be cleaned and re-installed.
4. The cold water basin drain should be left open.
5. The fan shaft bearings and motor base adjusting screws should be lubricated. This should also be performed if the unit is going to sit idle prior to initial start-up.
6. The make-up water supply, overflow and drain lines, as well as the recirculating pump and pump piping up to the overflow level must be heat traced and insulated to account for any residual water.
7. The finish of the unit should be inspected. Clean and refinish as required.
8. The fan, motor and pump bearings need to be turned at least once a month by hand. This can be accomplished by making sure the unit's disconnect is tagged and locked out, and grasping the fan assembly, rotating it several turns.
9. Closed Circuit Coolers only - If the recommended minimum fluid flows thru the heat transfer coil cannot be maintained, and an anti-freeze solution is not in the coil, the coil must be drained immediately whenever the system pumps are shut down or flow stops during freezing conditions. This is accomplished by having automatic drain valves and air vents in the piping to and from the cooler. Care must be taken to ensure that the piping is adequately insulated and sized to allow the water to flow quickly from the coil. This method of protection should be used only in emergency situations and is neither a practical nor recommended method of freeze protection. Coils should not be drained for an extended period of time, as internal corrosion may occur. See Cold Weather Operation section of this document for more details.

See fan and pump manufacturer maintenance and long term storage instructions for more detailed instructions.

Basic Closed Circuit Cooler/Condenser Sequence of Operation

Note: The eco-ATW/eco-ATWE sequence of operation is unique and is explained in detail in the Sage², Sage³ Panel Control Manual.

System Off / No Load

The system pumps and fans are off. If the basin is full of water a minimum basin water temperature of 40°F must be maintained to prevent freezing. This can be accomplished with the use of optional basin heaters. See the "Cold Weather Operation" section of this bulletin for more details on cold weather operation and maintenance.

System/Condensing Temperature Rises

The recirculation pump turns on. The unit will provide approximately 10% cooling capacity with only the pump running. If the unit has positive closure dampers they should be fully opened before the pumps turn on.

If the system temperature continues to rise, the unit fan is cycled on. For a variable speed controller, the fans are turned on to minimum speed. See the "Fan System – Capacity Control" section of this bulletin for more details on fan speed control options. If the system temperature continues to rise, then the fan speed is increased as required, up to full speed.

Note: During sub-freezing weather the minimum recommended speed for variable speed controllers is 50%. ALL FANS IN OPERATING CELLS OF MULTIPLE CELL UNITS MUST BE CONTROLLED TOGETHER TO PREVENT ICING ON THE FANS.

System Temperature Stabilizes

Control the leaving fluid temperature (closed circuit coolers) or condensing temperature (evaporative condensers) by modulating the fan speeds with variable speed drives or by cycling fans on and off with single or two-speed drives.

System/Condensing Temperature Drops

Decrease the fan speed, as required.

System Off / No Load

The system pump turns off. The starter interlock will energize any optional basin heaters in cold weather.

The recirculation pump should not be used as a means of capacity control, and should not be cycled frequently. Excessive cycling can lead to scale build-up, and reduce wet and dry performance.

Dry Operation

During colder winter months it is possible to turn off the spray pump, drain the cold water basin, and just cycle the fans. Be sure to leave the basin drain open during this time to prevent collection of rain water, snow, etc. If the unit has positive closure dampers they should be fully opened before the fans turn on. If this method will be used on a centrifugal fan, forced draft unit, be sure to verify that the motor and drives have been properly sized to handle the reduction in static pressure experienced when the spray water is turned off.

NOTE: MINIMUM CONTROL POINT FOR PROCESS FLUID SHOULD NEVER BE LOWER THAN 42° F.

NOTE: WHEN A UNIT IS PROVIDED WITH A DISCHARGE DAMPER ASSEMBLY, THE CONTROL SEQUENCE SHOULD CYCLE THE DAMPERS OPEN AND CLOSED ONCE A DAY REGARDLESS OF CAPACITY REQUIREMENTS TO PREVENT THE ASSEMBLY FROM SEIZING. THE FAN MOTOR SHOULD BE SHUT OFF WHENEVER THE DAMPERS ARE CLOSED.

Fan System

The fan systems of both centrifugal and axial driven units are rugged; however, the fan system must be checked regularly and lubricated at the proper intervals. The following maintenance schedule is recommended.

Fan Motor Bearings

EVAPCO evaporative cooling units use either a T.E.A.O. (Totally Enclosed Air Over) or a T.E.F.C. (Totally Enclosed Fan Cooled) fan motor. These motors are built to "Cooling Tower Duty" specifications. They are supplied with permanently lubricated bearings and special moisture protection on the bearings, shaft and windings. After extended shut-downs, the motor should be checked with an insulation tester prior to restarting the motor.

Fan Shaft Ball Bearings

For induced draft units, lubricate the fan shaft bearings every 1,000 hours of operation or every three months. For forced draft units, lubricate the fan shaft bearings every 2,000 hours of operation or every six months. Use any of the following synthetic waterproof, polyurea inhibited greases which are suitable for operation between -20°F and 350°F. (For colder operating temperatures, contact the factory).

Mobil – Polyrex EM

Chevron - SRI

Timken Pillowblock Grease

Feed grease slowly into the bearings or the seals may be damaged. A hand grease gun is recommended for this process. When introducing new grease, all grease should be purged from the bearings.

Most EVAPCO units are supplied with extended grease lines to allow easy lubrication of the fan shaft bearings as shown in Table 1.

Unit Description	Location of Lube Line Fittings
Induced Draft Units (Except MTW/MTC): 3', 4', 8', 8.5', 17' wide	Located just beside the fan casing access door
Induced Draft Units (Except MTW/MTC): 10', 12', 14', 24', 28' wide	Located inside the fan casing access door
Forced Draft Units	Located on the bearing support or on the side of the unit
MTW/MTC Internally Mounted Motors	Direct Drive. No bearing to lube
MTW/MTC Externally Mounted Motors	Motor adjustment plate

Table 1 – Location of Grease Lube Line Fittings for Belt Driven Units

Fan Shaft Sleeve Bearings – (4' wide LS units only)

Lubricate the intermediate sleeve bearing(s) before unit start up. The reservoir should be checked several times during the first week to ensure that the oil reserve is brought to full capacity. After the first week of operation, lubricate the bearing(s) every 1,000 hours of operation or every three months (whichever occurs first). High temperatures or poor environmental conditions may necessitate more frequent lubrication. The oil reservoir consists of a large felt packed cavity within the bearing housing. It is not necessary to maintain the oil level within the filler cup.

Use one of the following industrial grade, non-detergent mineral oils. **Do not use a detergent based oil or oils designated heavy duty or compounded.** Different oils may be required when operating at temperatures below 30°F continuously. Table 2 provides a short list of approved lubricants for each temperature range. Most automotive oils are detergent based and may not be used. Detergent oils will remove the graphite in the bearing sleeve and cause bearing failure.

Ambient Temp	Texaco	Mobil	Exxon
30°F to 100°F	Regal R&O 220	DTE Oil BB	Teresstic 220
-25°F to 30°F	Capella WF 32	DTE Heavy	-----

Table 2 – Sleeve Bearing Lubricants

All bearings used on EVAPCO equipment are factory adjusted and self aligning. Do not disturb bearing alignment by tightening the sleeve bearing caps.

Oil drippage may result from over-oiling or from using too light of an oil. Should this condition persist with correct oiling, it is recommended that a heavier weight oil be used.

Fan Belt Adjustment

The fan belt tension should be checked at start up and again after the first 24 hours of operation to correct for any initial stretch. To properly adjust the belt tension, position the fan motor so that the fan belt will deflect approximately 3/8" when moderate pressure is applied midway between the sheaves. Figure 1 and Figure 2 show two ways to measure this deflection. Belt tension should be checked on a monthly basis. A properly tensioned belt will not "chirp" or "squeal" when the fan motor is started.

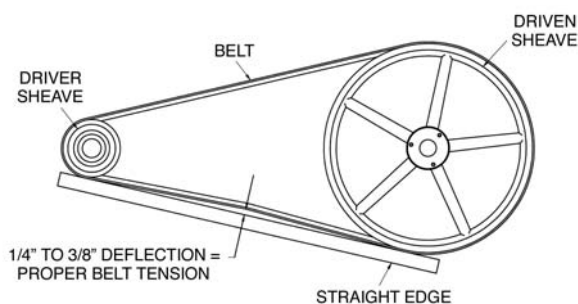

Figure 1 – Method 1

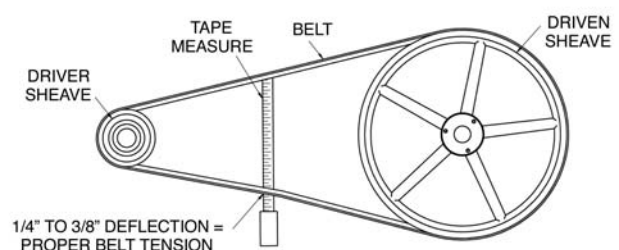

Figure 2 – Method 2

On induced draft belt driven units provided with externally mounted motors (3, 4, 8, 8.5 and 17 foot wide units) and LS, PM and MT Style forced draft units, both J-type adjustment bolts on the adjustable motor base should have an equal amount of exposed thread for proper sheave and belt alignment. See Figures 3, 4 & 7.

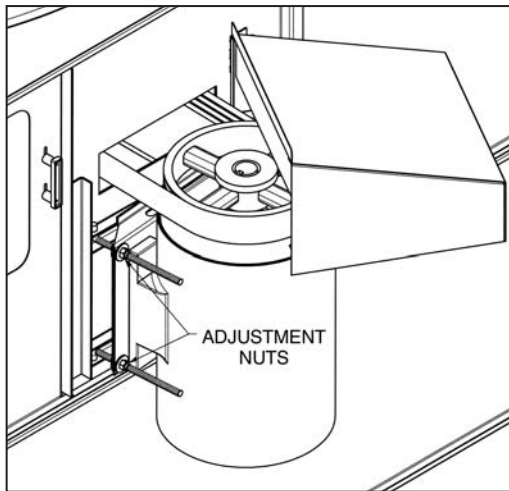

Figure 3 – Externally Mounted Motor, Induced Draft

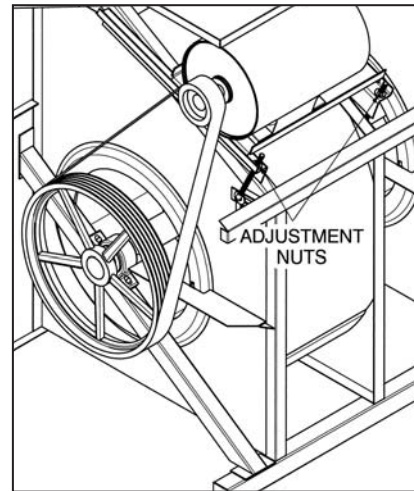

Figure 4 – Externally Mounted Motor, Large LS Units

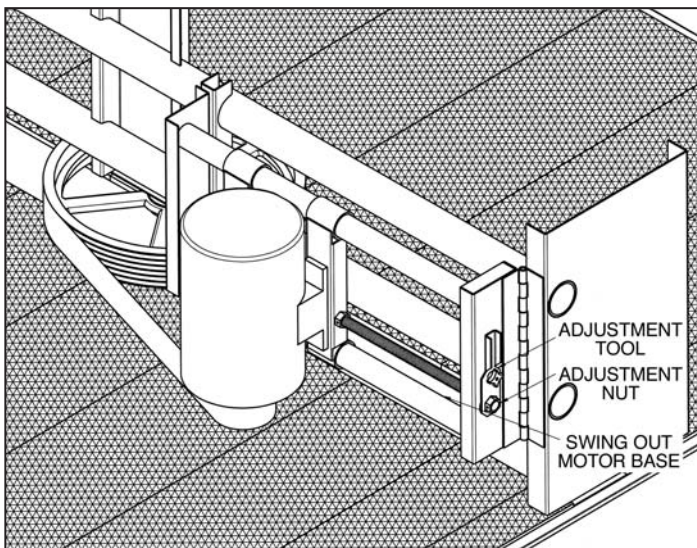

Figure 5 – Internally Mounted Motor, Induced Draft

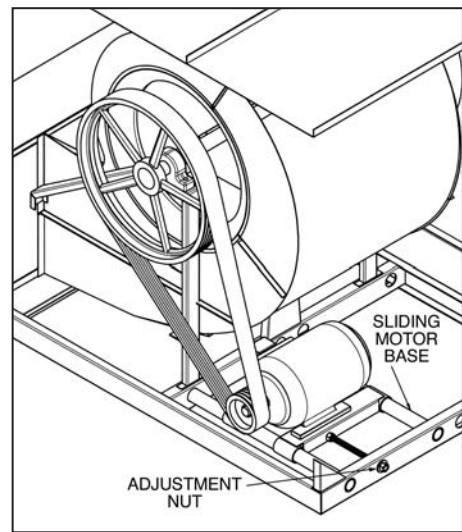

Figure 6 – LR Motor Adjustment

On induced draft belt driven units with internally mounted motors (10, 12, 14, 20, 24 and 28 foot wide units) and LR units, a motor adjustment tool is provided on the adjustment nut. See Figures 5 and 6. To use, place the hex end over the adjustment nut and tension the belt by turning the nut counterclockwise. When the belts are properly tensioned, tighten the lock nut.

Direct drive units do not require any adjustment.

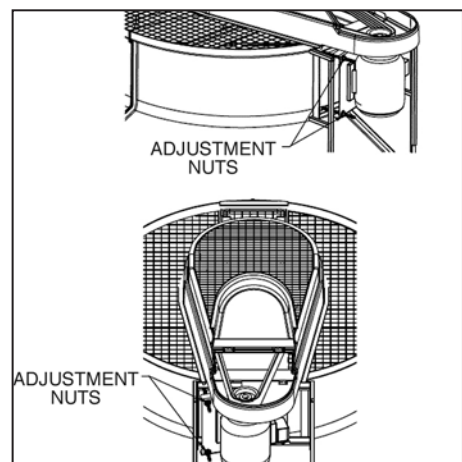

Figure 7 – Externally Mounted Motor, MT Units



Gear Drives

Induced draft units with gear drive systems require special maintenance. Please refer to the gear manufacturers recommended maintenance instructions. These will be enclosed and shipped with the unit.

Air Inlet

Inspect the air inlet louvers (induced draft units) or fan screens (forced draft units) monthly to remove any paper, leaves or other debris that may be blocking airflow into the unit.

Fan System — Capacity Control

There are several methods for capacity control of the evaporative cooling unit. Methods include: Fan motor cycling, the use of two speed motors, and the use of variable frequency drives (VFD's).

Note: for the eco-ATW with Sage² and eco-ATWE with Sage³ consult the manual.

Fan Motor Cycling

Fan Motor Cycling requires the use of a single stage thermostat which senses the fluid temperature (closed circuit coolers) or condensing temperature (evaporative condensers). The contacts of the thermostat are wired in series with the fan motor's starter holding coil.

Sequence of Operation for Fan Motor Cycling

Fan Motor Cycling is often found to be inadequate where the load has a wide fluctuation. In this method, there are only two stable levels of performance: 100% of capacity when the fan is on, and approximately 10% of capacity when the fan is off. Please note that rapid cycling of the fan motors can cause the fan motor to overheat. Controls should be set to only allow a maximum of six start/stop cycles per hour. The recirculation pump may not be used as a means of capacity control and should not be cycled frequently. Excessive cycling can lead to scale build-up, resulting in reduced wet and dry performance.

Two Speed Motors

The use of a two-speed motor provides an additional step of capacity control when used with the fan cycling method. The low speed of the motor will provide approximately 60% of full speed capacity.

Two-speed capacity control systems require not only a two-speed motor, but also a two-stage thermostat and the proper two-speed motor starter. The most common two-speed motor is a single winding type. This is also known as a consequent pole design. Two-speed two-winding motors are also available. All multi-speed motors used in evaporative cooling units should be variable torque design.

It is important to note that when two-speed motors are to be used, the motor starter controls must be equipped with a decelerating time delay relay. The time delay should be a minimum of 30 seconds when switching from high speed to low speed.

Sequence of Operation for Two Cell Units with Two Speed Motors during Peak Load

For eco-ATWE, see Sage²/Sage³ control Panel O&M

1. Both fan motors off – Pump running on one cell.
2. Both fan motors off – Pump running on both cells.
3. One fan motor on low speed, one fan motor off – Pump running on both cells.
4. Both fan motors on low speed – Pump running on both cells.
5. One fan motor on high speed, one fan motor on low speed – Pump running on both cells.
6. Both fan motors on full speed – Pump running on both cells.

Variable Frequency Drives

The use of a variable frequency drive (VFD) provides the most precise method of capacity control. A VFD is a device that converts a fixed AC voltage and frequency into an adjustable AC voltage and frequency used to control the speed of an AC motor. By adjusting the voltage and frequency, the AC induction motor can operate at many different speeds.

The use of VFD technology can benefit the life of the mechanical components with fewer and smoother motor starts and built-in motor diagnostics. VFD technology has particular benefit on evaporative cooling units operating in cold climates where airflow can be modulated to minimize icing and reversed at low speed for de-icing cycles. Applications using a VFD for capacity control must also use an inverter duty motor built in compliance with NEMA standard MG-1. This is an available option from EVAPCO.

NOTE: VFD's should not be used on pump motors. The pumps are designed to be operated at full speed and are not intended to be used as capacity control.

The type of motor, manufacturer of the VFD, motor lead lengths (between the motor and the VFD), conduit runs and grounding can dramatically affect the response and life of the motor. Select a high quality VFD that is compatible with the fan motor(s) in the EVAPCO unit(s). Many variables in the VFD configuration and installation can affect motor and VFD performance. Two particularly important parameters to consider when choosing and installing a VFD are switching frequency and the distance between the motor and VFD often referred to as lead length. Consult the VFD manufacturer's recommendations for proper installation and configuration. The motor lead length restrictions can vary with the vendor. Regardless of motor supplier, minimizing lead length between the motor and drive is good practice.

Sequence of Operations / Guidelines for Multi-fan Units with a VFD during Peak Load

For eco-WE, see Sage²/Sage³ control Panel O&M

1. Both fan motors off – Pump running on one cell.
2. Both fan motors off – Pump running on both cells.
3. Both VFDs turn on at the manufacturer's recommended minimum operating speed (20-25%) – Pump running on both cells.
4. Both VFDs speed up uniformly (they should be synchronized on start-up) – Pump running on both cells.
5. Both VFDs are on full speed – Pump running on both cells.

Note: the VFDs need to have a pre-set shutoff to prevent water temperatures from becoming too cold and to prevent the drive from trying to turn the fan at near zero speed. Operating below 25% of motor speed achieves very little return in fan energy savings and capacity control. Check with your VFD supplier if operating below 25% is possible.

For more details on the use of variable frequency drives, please download a copy of EVAPCO's Engineering Bulletin 39 from www.evapco.com.

Recirculated Water System – Routine Maintenance

Suction Strainer in Cold Water Basin

The pan strainer as shown in Figures 8, 9, 10, 11, 12 and 13 should be removed and cleaned monthly or as often as necessary. The suction strainer is the first line of defense in keeping debris out of the system. Make certain that the strainer is properly located over the pump suction, alongside the anti-vortexing hood.

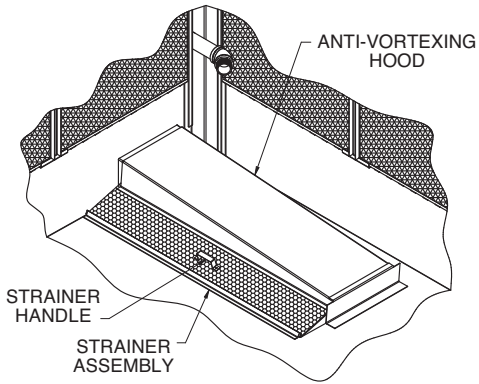

Figure 8 – Single Strainer Assembly

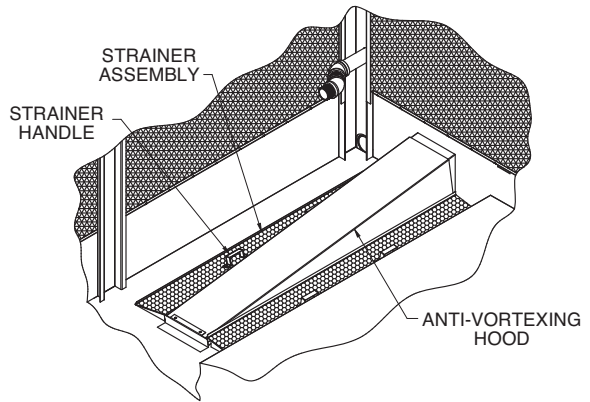

Figure 9 – Dual Strainer Assembly

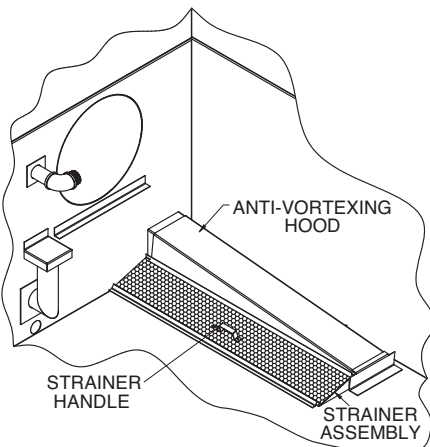

Figure 10 – LSWB/LSC-E/PMC-E/PMWQ Strainer Assembly

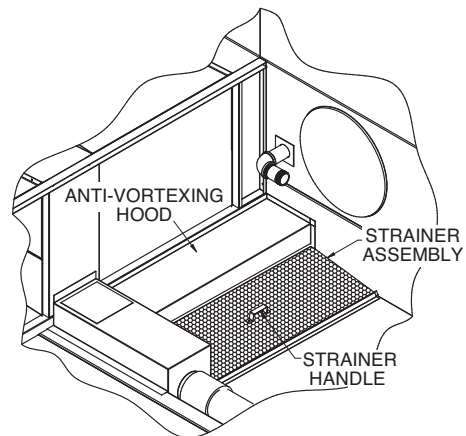

Figure 11 – LRWB/LRC Strainer Assembly

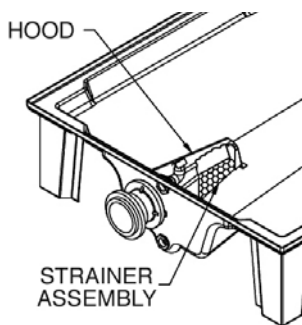

Figure 12 – MTW/C Strainer Assembly V-Sump

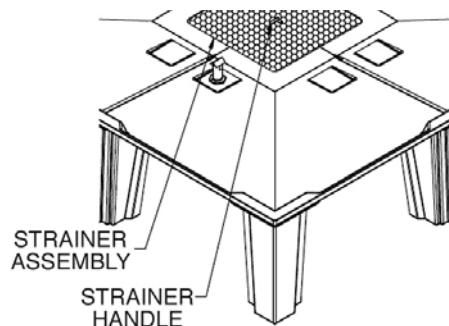

Figure 13 – MTW/C Strainer Assembly Depressed Sump

Cold Water Basin

The cold water basin should be flushed out quarterly, and checked monthly or more often if necessary, to remove any accumulation of dirt or sediment which normally collects in the basin. Sediment can become corrosive and cause deterioration of basin materials. When flushing the basin, it is important to keep the suction strainers in place to prevent any sediment from entering the system. After the basin has been cleaned, the strainers should be removed and cleaned before refilling the basin with fresh water.

Operating Level of Water in Cold Water Basin

The operating level should be checked monthly to make sure the water level is correct. Refer to Table 3 for unit specific levels.

Evaporative Condenser Model Number	Closed Circuit Cooler Footprint	Operating Water Level*
ATC-E & eco-ATC Products 50E to 165E 187E to 3714E	ATWB, eco-ATW & eco-ATWE Products 3' and 4' wide units** 8.5' wide thru 24' wide	9" 11"
eco-ATC Products 176 to 4068	8.5' wide thru 24' wide	11"
CATC Products 181 to 504	CATW Products 7.5' wide units	11"
MTC Products 47 to 206 222 to 487	MTW Products 4-3FG to 8-5J8 10-3G10 to 12-6N12	4"† 4"†
LRC Products 25 to 379	LRWB Products 3' wide thru 8' wide units	8"
LSC-E Products 36 to 170 185 to 385 400 to 515, 800 to 1030 550 to 805, 1100 to 1610 — — —	LSW Products 4'x6' thru 4'x12' 5.5'x12', 5.5'x18' 8'x12', 8'x24', 10'x12', 10'x24' 8'x18', 8'x36', 10'x18', 10'x36' Dual Fan Sided Units 8'x12', 8'x24' 8'x18', 8'x36'	11" 11" 12" 15" 12" 12" 15"
PMC-E Products 175E to 375E 332E to 1985E —	PMWQ Products — 10' and 12' wide units	10" 14"
—	ESWB Products 8.5' wide and 2.4M wide 12' wide	9" 10"
—	ESWA Products 8.5' wide thru 14' wide units	11"

* Measured from lowest point on basin floor.

** Not available on eco-ATWE.

† Measured from the overflow.

Table 3 - Recommended Operating Water Level

At initial start up or after the unit has been drained, the unit must be filled to the overflow level. Overflow is above the normal operating level and accommodates the volume of water normally in suspension in the water distribution system and the riser piping.

The water level should always be above the strainer. Check by running the pump with the fan motors off and observing the water level through the access door or remove the air inlet louver.

Water Make Up Valve

A mechanical float valve assembly is provided as standard equipment on the evaporative cooling unit (unless the unit has been ordered with an optional electronic water level control package or the unit is arranged for remote sump operation). The make up valve is easily accessible from outside the unit through the access door or removable air inlet louver. The make up valve is a bronze valve connected to a float arm assembly and is activated by a large foam filled plastic float. The float is mounted on an all-thread rod held in place by wing nuts. The water level in the basin is adjusted by repositioning the float and all-thread using the wing nuts. Refer to Figure 14 for details.

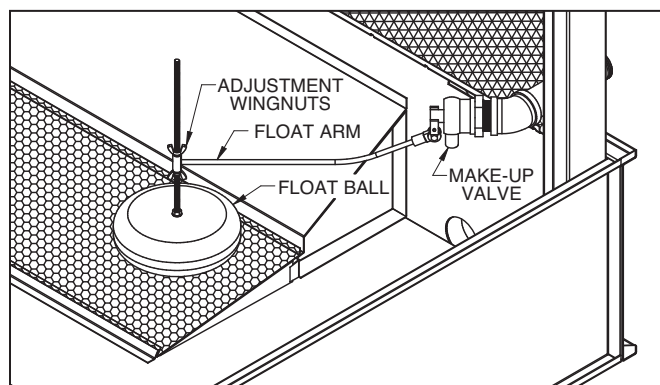

Figure 14 – Mechanical Water Make Up Valve

-The make up valve assembly should be inspected monthly and adjusted as required. The valve should be inspected annually for leakage and if necessary, the valve seat should be replaced. The make up water pressure for the mechanical valve should be maintained between 20 and 50 PSIG.

Pressurized Water Distribution Systems

Check the water distribution system monthly to make sure it is operating properly. Always check the spray system with the pump on and the fans off. On forced draft models, remove one or two eliminator sections from the top of the unit and observe the operation of the water distribution system. On induced draft models, lifting handles are provided along the top layer of eliminators. Eliminators can be easily removed from the access door and the distribution system observed. The diffusers are essentially non-clogging and should seldom need cleaning or maintenance.

If the water diffusers are not functioning properly, it is a sign that the pan or system strainer has not been working properly and that foreign matter or dirt has accumulated in the water distribution pipes. The nozzles can be cleared by taking a small pointed probe and moving it rapidly back and forth in the diffuser opening.

If an extreme build-up of dirt or foreign matter occurs, remove the end cap in each branch to flush the debris from the header pipe. The branches or header can be removed for cleaning, but do so only if necessary. Check the strainer in the pan to make sure it is in good condition and positioned properly so that cavitation or air entrainment does not occur.

All Evaporative Condensers and Closed Circuit Coolers, except the ESWA Closed Circuit Cooler, are supplied with ZMII® spray nozzles as standard. The ZMII® spray nozzles do not need to be oriented a specific way to achieve proper coil coverage. Figure 13 shows the standard orientation of the ZMII® spray nozzles.

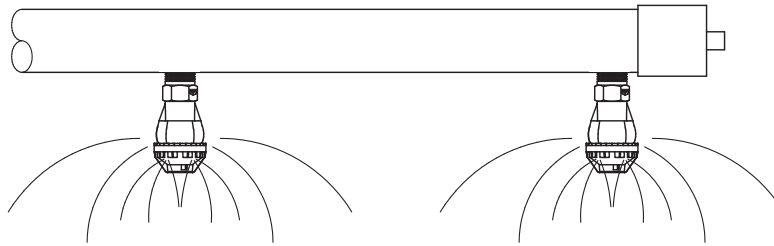

Figure 15 – ZMII® Spray Nozzle Orientation
All Coil Products except the ESWA

For the ESWA, wide orifice water diffusers are supplied. When inspecting and cleaning the water distribution system, always check that the orientation of the water diffusers is correct as shown in Figures 16 and 17. For EvapJet nozzles, make sure that the top edge of the “EVAPCO” logo is parallel to the top of the water distribution pipe.

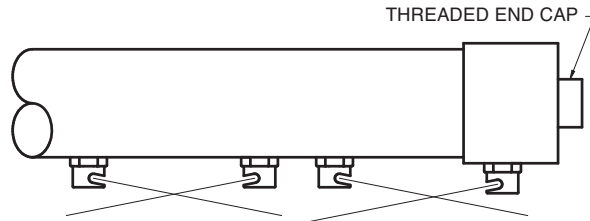

Figure 16 – Proper Water Diffuser Orientation (2A Nozzles)
ESWA Models (Except 14' Wide Models)

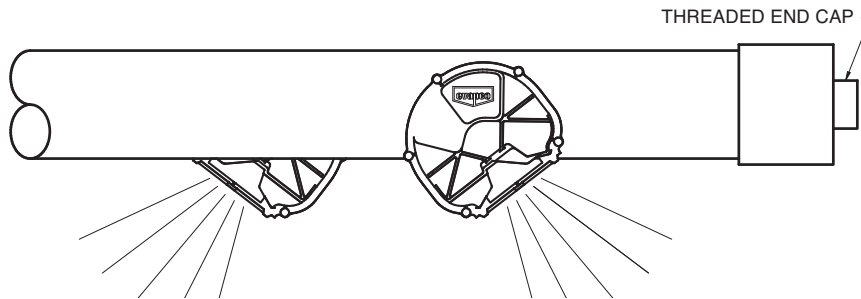

Figure 17 – Proper Water Diffuser Orientation (EvapJet)
ESWA 14' Wide Models

Bleed-Off Valve

The bleed-off valve, whether factory or field installed, must be checked weekly to make sure it is functioning and set properly. Keep the bleed-off valve wide open unless it has been determined that it can be set partially open without causing scaling or corrosion.

Pump (When Supplied)

The pump and pump motor should be lubricated and serviced in accordance with the pump manufacturer’s instructions as supplied with the unit. The recirculation pump should not be used as a means of capacity control, used with a VFD or be cycled frequently. Excessive cycling can lead to scale build-up, and reduce wet and dry performance. On 14' wide ESWA's, which are supplied with two pumps per cell, both pumps should be energized at the same time. One pump should not be on while the other pump is off.

Note: for the eco-ATWE, please consult the Sage² and Sage³ manual.

The pump motor fan and impeller should be turned by hand if the pump assembly sits idle.

Water Treatment and Water Chemistry

Proper water treatment is an essential part of the maintenance required for evaporative cooling equipment. A well designed and consistently implemented water treatment program will help to ensure efficient system operation while maximizing the equipment's service life. A qualified water treatment company should design a site specific water treatment protocol based on equipment (including all metallurgies in the cooling system), location, makeup water quality, and usage.

Bleed or Blowdown

Evaporative cooling equipment rejects heat by evaporating a portion of the recirculated water into the atmosphere as warm, saturated discharge air. As the pure water evaporates it leaves behind the impurities found in the system's makeup water and any accumulated airborne contaminants. These impurities and contaminants, which continue to recirculate in the system, must be controlled to avoid excessive concentration which can lead to corrosion, scale, or biological fouling.

Evaporative cooling equipment requires a bleed or blowdown line, located on the discharge side of the recirculating pump, to remove concentrated (cycled up) water from the system. EVAPCO recommends an automated conductivity controller to maximize the water efficiency of your system. Based on recommendations from the water treatment company, the conductivity controller should open and close a motorized ball or solenoid valve to maintain the conductivity of the recirculating water. If a manual valve is used to control the rate of bleed it should be set to maintain the conductivity of the recirculating water during periods of peak load at the maximum level recommended by the water treatment company.

Galvanized Steel – Passivation

'White Rust' is a premature failure of the protective zinc layer on hot dip or mill galvanized steel which can occur as a result of improper water treatment control during the start-up of new galvanized equipment. The initial commissioning and passivation period is a critical time for maximizing the service life of galvanized equipment. EVAPCO recommends that the site specific water treatment protocol includes a passivation procedure which details water chemistry, any necessary chemical addition, and visual inspections during the first six (6) to twelve (12) weeks of operation. During this passivation period, recirculating water pH should be maintained above 7.0 and below 8.0 at all times. Since elevated temperatures have a harmful effect on the passivation process, the new galvanized equipment should be run without load for as much of the passivation period as is practical.

The following water chemistry promotes the formation of white rust and should be avoided during the passivation period:

1. pH values in the recirculating water greater than 8.3.
2. Calcium hardness (as CaCO₃) less than 50 ppm in the recirculating water.
3. Anions of chlorides or sulfates greater than 250 ppm in the recirculating water.
4. Alkalinity greater than 300 ppm in the recirculating water regardless of pH value.

Changes in water chemistry control may be considered after the passivation process is complete as evidenced by the galvanized surfaces taking on a dull gray color. Any changes to the treatment program or control limits should be made slowly, in stages while documenting the impact of the changes on the passivated zinc surfaces.

- Operating galvanized evaporative cooling equipment with a water pH below 6.0 for any period may cause removal of the protective zinc coating.
- Operating galvanized evaporative cooling equipment with a water pH above 9.0 for any period may destabilize the passivated surface and create white rust.
- Re-passivation may be required at any time in the service life of the equipment if an upset condition occurs which destabilizes the passivated zinc surface.

For more information on passivation and white rust, please download a copy of EVAPCO's Engineering Bulletin 36 at www.evapco.com.

Water Chemistry Parameters

The water treatment program designed for evaporative cooling equipment must be compatible with the unit’s materials of construction. Control of corrosion and scale will be very difficult if the recirculating water chemistry is not consistently maintained within the ranges noted in Table 4. In mixed metallurgy systems, the water treatment program should be designed to ensure protection of all the components used in the cooling water loop.

Property	G-235 Galvanized Steel	Type 304 Stainless Steel	Type 316 Stainless Steel
pH	7.0 – 8.8	6.0 – 9.5	6.0 – 9.5
pH During Passivation	7.0 – 8.0	N/A	N/A
Total Suspended Solids (ppm)*	< 25	< 25	< 25
Conductivity (Micro-mhos/cm) **	< 2,400	< 4,000	< 5,000
Alkalinity as CaCO ₃ (ppm)	75 - 400	< 600	< 600
Calcium Hardness CaCO ₃ (ppm)	50 - 500	< 600	< 600
Chlorides as Cl (ppm) ***	< 300	< 500	< 2,000
Silica (ppm)	< 150	< 150	< 150
Total Bacteria (cfu/ml)	< 10,000	< 10,000	< 10,000

* Based on standard EVAPAK® fill

** Based on clean metal surfaces. Accumulations of dirt, deposits, or sludge will increase corrosion potential

*** Based on maximum coil fluid temperatures below 120°F (49°C)

Table 4 – Recommended Water Chemistry Guidelines

If a chemical water treatment program is used, all chemicals selected must be compatible with the unit’s materials of construction as well as other equipment and piping used in the system. Chemicals should be fed through automatic feed equipment to a point which ensures proper control and mixing prior to reaching the evaporative cooling equipment. Chemicals should never be batch fed directly into the basin of the evaporative cooling equipment.

Evapco does not recommend the routine use of acid due to the destructive consequences of improper feeding; however, if acid is used as part of the site specific treatment protocol, it should be pre-diluted prior to introduction into the cooling water and fed by automated equipment to an area of the system which ensures adequate mixing. The location of the pH probe and acid feed line should be designed in conjunction with the automated feedback control to ensure that proper pH levels are consistently maintained throughout the cooling system. The automated system should be capable of storing and reporting operational data including pH reading and chemical feed pump activity. Automated pH control systems require frequent calibration to ensure proper operation and to protect the unit from increased corrosion potential.

The use of acids for cleaning should also be avoided. If acid cleaning is required, extreme caution must be exercised and only inhibited acids recommended for use with the unit’s materials of construction should be used. Any cleaning protocol, which includes the use of an acid, shall include a written procedure for neutralizing and flushing the evaporative cooling system at the completion of the cleaning.

Control of Biological Contamination

Evaporative cooling equipment should be inspected regularly to ensure good microbiological control. Inspections should include both monitoring of microbial populations via culturing techniques and visual inspections for evidence of biofouling.

Poor microbiological control can result in loss of heat transfer efficiency, increase corrosion potential, and increase the risk of pathogens such as those that cause Legionnaires’ disease. The site specific water treatment protocol should include procedures for routine operation, startup after a shut-down period, and system lay-up, if applicable. If excessive microbiological contamination is detected, a more aggressive mechanical cleaning and/or water treatment program should be undertaken.



It is important that all internal surfaces, particularly the basin, be kept clean of accumulated dirt and sludge. Additionally, drift eliminators should be inspected and maintained in good operating condition.

Gray Water and Reclaimed Water

The use of water reclaimed from another process as a source of makeup water for evaporative cooling equipment can be considered as long as the resultant recirculating water chemistry conforms to the parameters noted in Table 4. It should be noted that using water reclaimed from other processes may increase the potential of corrosion, microbiological fouling, or scale formation. Gray water or reclaimed water should be avoided unless all of the associated risks are understood and documented as part of the site specific treatment plan.

Air Contamination

Evaporative cooling equipment draws in air as part of normal operation and can scrub particulates out of the air. Do not locate the unit next to smokestacks, discharge ducts, vents, flue gas exhausts, etc. because the unit will draw in these fumes which may lead to accelerated corrosion or deposition potential within the unit. Additionally, it is important to locate the unit away from the building's fresh air intakes to prevent any drift, biological activity, or other unit discharge from entering the building's air system.

Cold Weather Operation

EVAPCO counterflow evaporative cooling equipment is well suited to operate in cold weather conditions. The counterflow design encases the heat transfer media (fill and/or coils) completely, and protects it from the outside elements such as wind which can cause freezing in the unit.

When the evaporative cooling unit is going to be used during cold weather conditions, several items need to be considered including unit layout, recirculating water, unit recirculating piping, unit heat transfer coils, unit accessories and capacity control of the units.

Unit Layout

Adequate unobstructed air flow must be provided for both the intake and discharge from the unit. It is imperative that the equipment minimize the risk of recirculation. Recirculation can result in condensation freezing the inlet louvers, fans and fan screens. The buildup of ice on these areas can adversely affect air flow and in more severe cases, lead to failure of these components. Prevailing winds can create icing conditions on the inlet louvers and fan screens adversely affecting airflow to the unit.

For additional information on unit layout, please refer to EVAPCO's Equipment Layout Manual.

Freeze Protection of Recirculating Water

The simplest and most effective way of keeping the recirculated water from freezing is to use a remote sump. With a remote sump, the recirculating water pump is mounted remotely at the sump and whenever the pump is shut off, all recirculating water drains back to the sump. Recommendations for sizing the remote sump tank and recirculating water pumps for coil products are presented for Evaporative Condensers and Closed Circuit Coolers in their respective catalog bulletin. The pressure drop through the water distribution system measured at the water inlet is as follows in Table 5.

If a remote sump cannot be used, basin heaters are available to keep the recirculating water from freezing when the pump is turned off. Electric heaters, hot water coils, steam coils or steam injectors may be used to heat the basin water when the unit is shut down. However, the basin heater will not prevent the external water lines, pump or pump piping from freezing. The make-up water supply, overflow and drain lines, as well as the pump and pump piping up to the overflow level must be heat traced and insulated to protect them from damage. Any other connections or accessories at or below the water level, such as electronic water level controllers, must also be heat traced and insulated.

Note: Using basin heaters will not prevent the fluid in the coils, nor the residual water in the pump or pump piping from freezing.

A condenser or cooler cannot be operated dry (fans on, pump off) unless the water is completely drained from the pan. The pan heaters are sized to prevent pan water from freezing only when the unit is completely shut down.

Evaporative Condenser Model Number		Closed Circuit Cooler Footprint	Required Inlet Pressure (psi)
ATC-E Products	eco-ATC Products	ATWB, eco-ATW & eco-ATWE Products	
50E to 165E	—	3' and 4' wide units**	2.0
170E to 247E	176 to 272	8.5'x7.5'	2.0
218E to 305E	226 to 334	8.5'x9'	2.0
246E to 473E	225 to 487	8.5'x10.5', 8.5'x12', 8.5'x14'	2.0
486E to 630E	447 to 668	8.5'x18'	3.0
508E to 755E	501 to 797	8.5'x21'	4.0
643E to 926E	658 to 1011	17'x12', 17'x14'	2.5
XE298E to XC462E, XE596E to XC925E	280 to 503, 559 to 1005	10'x12', 10'x24', 20'x12'	3.7
XE406E to XC669E, XE812E to XC1340E	365 to 705, 731 to 1411	10'x18', 10'x36', 20'x18'	5.7
428E to 892E	433 to 644, 557 to 710, 636 to 942	12'x12', 12'x14', 12'x18'	3.5
858E to 1784E	866 to 1288, 1176 to 1420, 1186 to 1883	12'x24', 12'x28', 12'x36'	2.5
857E to 1783E	867 to 1289, 1177 to 1421, 1187 to 1884	24'x12, 24'x14', 24'x18'	3.0
1879E to 3459E	1844 to 2572, 2353 to 2841, 2545 to 3766	24'x24', 24'x28', 24'x36'	2.5
791E to 967E, 1625E to 1925E	775 to 1023, 1607 to 2043	12'x20', 12'x40'	3.5
1616E to 1915E, 2855E to 3714E	1608 to 2044, 2911 to 4086	24'x20', 24'x40'	3.2
CATC Products		CATW Products	
181 thru 373		7.5'x8', 7.5'x12', 7.5'x14'	2.0
362 thru 504		7.5'x18'	3.0
LRC Products		LRWB Products	
25 to 72		3' wide units	1.0
76 to 114		5'x6'	2.0
108 to 183		5'x9'	2.0
190 to 246		5'x12'	2.0
188 to 379		8' wide units	2.0
LSC-E Products		LSWE Products	
36 to 80		4'x6'	1.5
90 to 120		4'x9'	1.5
135 to 170		4'x12', 4'x18'	1.5
185 to 385		5.5'x12', 5.5'x18'	2.0
400 to 1610		10'x12', 10'x18', 10'x24', 10'x36'	2.5
		8'x12', 8'x18', 8'x24', 8'x36'	3.0
		Dual Fan Sided Units	
		8'x12', 8'x18', 8'x24', 8'x36'	2.5
		ESWA Products	
		8.5'x9'	3.0
		8.5'x12'	2.5
		8.5'x18'	3.5
		12'x12'	3.0
		12'x18'	2.5
		14'x24', 14'x48'	3.0
PMC-E Products		PMWQ Products	
175E to 375E		—	2.0
332E to 1556E		10' wide units	3.0
420E to 1985E		12' wide units	3.5

Note: For multi-cell units, the inlet pressure shown is per cell.

** Not available as eco-ATWE

Table 5 - Required Recirculating Water Inlet Pressure for Remote Sump Application - Coil Products Only

Freeze Protection of Closed Circuit Cooler Coils

The simplest and most effective way of protecting the heat exchanger coil from freezing is to use an inhibited ethylene or propylene glycol anti-freeze. If this is not possible, an auxiliary heat load and minimum flow rate must be maintained on the coil at all times so that the water temperature does not drop below 50°F when the cooler is shut down. See Table 6 for recommended minimum flow rates.

If an anti-freeze solution is not used, the coil must be drained immediately whenever the pumps are shut down or flow stops. This is accomplished by having automatic drain valves and air vents in the piping to and from the cooler. Care must be taken to ensure that the piping is adequately insulated and sized to allow the water to flow quickly from the coil. This method of protection should be used only in emergency situations and is neither a practical nor recommended method of freeze protection. Coils should not be drained for an extended period of time, as internal corrosion may occur.

When the unit is in operation during freezing weather, some type of capacity control is normally required in order to keep water temperatures from dropping below 50°F. Operating dry with a remote sump is an excellent way of reducing unit capacity at low temperatures. Other methods of capacity control include two-speed motors, VFDs and fan cycling. These can be used individually or in combination with dry/remote sump operation.

Closed Circuit Cooler Footprint	Minimum Flows	
	Standard Flow GPM	Series Flow GPM
ATWB Products, eco-ATW & eco-ATWE		
3'x3' ^{**}	—	26
4' wide units ^{**}	74	37
8.5'x7.5'	148	74
8.5'x9' to 8.5'x21'	160	80
17'x12', 17'x14'	320	160
10'x12', 10'x18'	188	94
10'x24', 10'x36', 20'x12', 20'x18'	376	188
20'x24', 20'x36'	752	376
12'x12', 12'x14', 12'x18', 12'x20'	232	116
12'x24', 12'x28', 12'x36', 12'x40'	464	232
24'x12', 24'x14', 24'x18', 24'x20'	464	232
24'x24', 24'x28', 24'x36', 24'x40'	928	464
CATW Products	140	70
MTW Products		
4'x6'	27.75	-
4'x9'	62.9	-
8'x8'	158.4	-
10'x10'	202.4	-
12'x12'	250.8	-
LRWB Products		
3' wide units	60	30
5' wide units	94	47
8' wide units	148	74
LSWE Products		
4'x6', 4'x9', 4'x12', 4'x18'	66	30
5.5'x12', 5.5'x18'	94	47
8'x12', 8'x18'	148	74
8'x24', 8'x36'	296	148
10'x12', 10'x18'	188	94
10'x24', 10'x36'	376	188
Dual Fan Side Units		
8'x12', 8'x18'	132	66
8'x24', 8'x36'	264	132
ESWA Products		
8.5'x9', 8.5'x12', 8.5'x18'	237	119
12'x12', 12'x18'	330	165
14'x24'	708	354
14'x48'	1416	708
PMWQ Products		
10'x12', 10'x18'	210	105
10'x24', 10'x36'	415	208
12'x12', 12'x18', 12'x20'	256	128
12'x24', 12'x36', 12'x40'	511	256

Table 6 - Closed Circuit Cooler Minimum Recommended Flow Rate

** Not available as eco-ATWE

Unit Accessories

The appropriate accessories to prevent or minimize ice formation during cold weather operation are relatively simple and inexpensive. These accessories include cold water basin heaters, the use of a remote sump, electric water level control and vibration cut out switches. Each of these optional accessories ensures that the cooler or condenser will function properly during cold weather operation.

Cold Water Basin Heaters

Optional basin heaters can be furnished with the unit to prevent the water from freezing in the basin when the unit is idle during low ambient conditions. The basin heaters are designed to maintain 40°F basin water temperature at a 0°F ambient temperature. The heaters are only energized when the recirculating pumps are off and no water is flowing over the heat exchanger coil. As long as there is a heat load and water is flowing over the heat exchanger coil, the heaters do not need to operate. Other types of basin heaters to consider would include: hot water coils, steam coils or steam injectors.

Remote Sumps

A remote sump located in an indoor heated space is an excellent way to prevent freezing in the cold water basin during idle or no load conditions because the basin and associated piping will drain by gravity whenever the recirculating pump is idle. EVAPCO units built for remote sump operation do not include recirculating water pumps.

Electric Water Level Control

Optional electric water level control packages can be furnished to replace the standard mechanical float and valve assembly. The makeup water pressure for electronic water level control should be maintained between 5 and 100 psig. The electric water level control eliminates the freezing problems experienced by the mechanical float. In addition, it provides accurate control of the basin water level and does not require field adjustment even under varying load conditions. Please note: the standpipe assembly, make up piping and solenoid valve must be heat traced and insulated to prevent them from freezing.

Vibration Cut Out Switches

During severe cold weather conditions, ice can form on the fans of cooling towers causing excessive vibration. The optional vibration switch shuts the fan off avoiding potential damage to or failure of the drive system.

Capacity Control Methods for Cold Weather Operation

Induced draft and forced draft coolers or condensers require separate guidelines for capacity control during cold weather operation.

The sequence of control for a unit operating at low ambient conditions is much the same as a cooler or condenser operating under summer conditions provided that the ambient temperature is above freezing. When the ambient temperatures are below freezing, additional precautions must be taken to avoid the potential for damaging ice formation.

The most effective way to avoid ice formation in and on a closed circuit cooler or condenser during the winter is to run the unit DRY. In dry operation, the recirculation pump is turned off, the basin drained, and air passes over the coil. Instead of using evaporative cooling to cool the process fluid or condense the refrigerant, sensible heat transfer is utilized, so there is no recirculation water to freeze. If this method will be used on a forced draft unit, be sure to verify that the motor and drives have been properly sized to handle the reduction in static pressure experienced when the spray water is turned off.

It is very important to maintain close control of the cooler or condenser during winter operation. EVAPCO recommends that an absolute MINIMUM leaving water temperature of 42° F must be maintained for cooler applications. The higher the leaving temperature from the cooler or condenser, the lower the potential for ice formation.

Induced Draft Unit Capacity Control

The simplest method of capacity control is cycling the fan motor on and off in response to the leaving fluid temperature of the cooler or condenser. However, this method of control results in larger temperature differentials and longer periods of down time. During extremely low ambient conditions, the moist air may condense and freeze on the fan drive system. Therefore, fans must be cycled during extremely low ambient conditions to avoid long periods of idle time when water is flowing over the coil. The number of start/stop cycles must be limited to no more than six per hour.

A better method of control is the use of two-speed fan motors. This allows an additional step of capacity control. This additional step reduces the water temperature differential, and therefore, the amount of time the fans are off. In addition, two-speed motors provide savings in energy costs, since the cooler or condenser has the potential to operate on low speed for the reduced load requirements.

The best method of capacity control during cold weather operation is the use of a variable frequency drive (VFD). This allows the closest control of the leaving water temperature by allowing the fan(s) to run at the appropriate speed to closely match the building load. As the building load decreases, the VFD control system may operate for long periods of time at fan speeds below 50%. Operating a low leaving water temperature and low air velocity through the unit can cause ice to form. It is recommended that the minimum speed of the VFD be set at 50% of full speed to minimize the potential for ice to form in the unit.

Forced Draft Unit Capacity Control

The most common methods of capacity control are cycling the single speed fan motors, using two-speed motors or pony motors and utilizing variable frequency drives to control the cooler or condenser fans. Although capacity control methods for forced draft units are similar to those used for induced draft units, there are slight variations.

The simplest method of capacity control for forced draft units is to cycle the fan(s) on and off. However, this method of control results in larger temperature differentials and periods of time with the fans off. When the fans are cycled off, the water falling through the unit can draw air flow into the fan section. During extremely low ambient conditions, this moist air may condense and freeze on the cold components of the drive system. When conditions change and cooling is needed, any amount of ice that has formed on the drive system can severely damage the fans and fan shafts. **Therefore, fans MUST be cycled during low ambient operation to avoid long periods of idle fan operation. Excessive cycling can damage the fan motors. Limit the number of cycles to a maximum of six per hour.**

Two speed or pony motors offer a better method of control. This additional step of capacity control will reduce water temperature differentials and the amount of time that the fans are off. This method of capacity control has proven effective for applications where load variations are excessive and cold weather conditions are moderate.

The use of a variable frequency drive provides the most flexible method of capacity control for forced draft units. The VFD control system allows the fans to run at nearly an infinite range of speeds to match the unit capacity to the system load. During periods of reduced load and low ambient temperatures, the fans must maintain enough speed to ensure positive air flow through the unit. This positive air flow in the unit will prevent moist air from migrating towards the cold fan drive components reducing the potential for condensation to form and freeze on them. The VFD control system should be implemented for applications that experience fluctuating loads and severe cold weather conditions.

Ice Management

When operating an evaporative cooling unit in extreme ambient conditions, the formation of ice is inevitable. The key to successful operation is to control or manage the amount of ice that builds up in the unit. If extreme icing occurs, it can lead to severe operational difficulties as well as potential damage to the unit. Following these guidelines will minimize the amount of ice that forms in the unit leading to better operation during the cold weather season.

Induced Draft Units

When operating an induced draft unit during the cold weather season, the control sequence must have a method to manage the formation of ice in the unit. The simplest method of managing the amount of ice buildup is by cycling the fan motors off while keeping the pump on. During these periods of idle fan operation, the warm water that is absorbing the building load flows thru the coil to help melt the ice that has formed in the coil, basin or louver areas. Warning: Using this method during periods of high winds can cause blow thru, resulting in splash-out and ice formation. To help prevent blow thru and splash-out, maintain a minimum 50% fan speed.

In more severe climates, the incorporation of a defrost cycle can be used to mitigate and/or eliminate any detrimental effects of ice in the unit. During the defrost cycle, the fans are reversed at **half speed** while the recirculating pump flows water through the unit's water distribution system. Operating the unit in reverse will melt any ice or frost that may have formed in the unit or on the air intake louvers. **The defrost cycle requires the use of two speed motors with reverse cycle starters or reversible variable frequency drives.** All motors supplied by EVAPCO are capable of reverse operation.

The defrost cycle should be incorporated into the normal control scheme of the cooler or condenser system. The control system should allow for either a manual or automatic method of controlling frequency and length of time required to completely defrost the ice from the unit. The frequency and length of the defrost cycle is dependent on the control methods and ambient cold weather conditions. Some applications will build ice quicker than others which may require longer and more frequent defrost periods. **Frequent inspection of the unit will help "fine-tune" the length and frequency of the defrost cycle.**

Forced Draft Units

Defrost cycles are NOT recommended for forced draft units, since allowing the leaving water temperature set point to rise causes the fans to be off for very long periods of time. This is not recommended for forced draft coolers or condensers because of the potential for freezing the fan drive components. Therefore, the defrost cycle is an inappropriate method of ice management for forced draft units. However, low speed fan operation or variable frequency drives maintain a positive pressure in the unit which helps prevent ice formation on the fan drive components.

For more information on cold weather operation, please download a copy of EVAPCO's Engineering Bulletin 23 at www.evapco.com

Troubleshooting

Problem	Possible Cause	Remedy
Overamping Fan Motors	Reduction in air static pressure	<ol style="list-style-type: none"> 1. On a forced draft unit verify that the pump is on, and water is flowing over the coil. If the pump is off, and the unit was not sized for dry operation, the motor may over-amp. 2. If the forced draft unit is ducted, verify that the design ESP matches the actual ESP. 3. Verify the correct pump rotation direction. If the pump is rotating incorrectly, it will result in less water flow, and therefore less overall static pressure. 4. Check the basin water level against the recommended level. <p>Note: Air density directly affects AMP reading. Low air density can cause the fans to spin faster, thus increasing the amp draw.</p>
	Electrical issue	<ol style="list-style-type: none"> 1. Check voltage across all three legs of the motor. 2. Verify that the motor is wired per the wiring diagram, and connections are tight.
	Fan rotation	Verify that the fan is rotating in the correct direction. If not, switch the leads so it runs correctly.
	Mechanical failure	Verify that the fan and motor turn freely by hand. If not, there may be damage to the internal motor components or bearings.
	Belt tension	Check for proper belt tension. Extreme belt tension can cause the motor to overamp.
Unusual Motor Noise	Motor running single-phase	Stop motor and attempt to start it. Motor will not start again if single phased. Check wiring, controls and motor.
	Motor leads connected incorrectly	Check motor connections against wiring diagram on motor.
	Bad bearings	Check lubrication. Replace bad bearings.
	Electrical unbalance	Check voltage and current of all three lines. Correct if required.
	Air gap not uniform	Check and correct bracket fits or bearing.
	Rotor unbalance	Rebalance.
	Cooling fan hitting end bell guard	Reinstall or replace fan.
Incomplete Spray Pattern	Nozzles clogged	Remove nozzles and clean. Flush water distribution system.
	Pump running backwards	Visually verify pump rotor rotation by turning pump off and then on. Verify amp draw.
	Inadequate pump flow for remote sump	Confirm inlet pressure at header meets required valves.
	Strainer clogged	Remove strainer and clean.



Operation and Maintenance Instructions

Problem	Possible Cause	Remedy
Fan Noise	Blade rubbing inside of fan cylinder (induced draft models)	Adjust cylinder to provide blade tip clearance.
Scaled Inlet Louvers on AT Units	Improper water treatment, insufficient bleed rates or excessive cycling of the fan motors, or high concentrations of solids in water.	Scale should not be removed using a power washer or wire brush because it could damage the louvers. Remove the louver assemblies and let them soak in the cold water basin of the unit. The water treatment chemicals in the unit will neutralize and dissolve the buildup of scale. Please note that the time required for soaking the inlet louvers depends on the severity of the scale buildup. Note: This assumes chemicals are being used.
Overamping Pump Motors	Initial start-up	If the unit has only run for a few hours, the pump may overamp until the pump wear ring has worn in. In this case, it would only be small percentages, not 15 or 20%. Normally, after a few hours, the pump amp readings will reduce and level off.
	Mechanical failure	Verify that the pump can turn freely by hand. If not, pump most likely needs to be replaced.
	Electrical issue	Verify that the pump has been wired properly. Verify that the voltage supplying the pump is correct.
	Misconception of head increase or decrease	Note: Increase or decrease in pump flow as a result of clogged or blown out nozzles or headers should NOT cause the pump to over amp.
Makeup Valve Will Not Shut Off	Make-up water pressure too high	Mechanical make-up valve water pressure must be between 20 and 50psi. If pressure is too high, the valve will not close. A pressure reducing valve can be added to lower the pressure. For the 3 and 5 Probe Electronic Water Level Control Package, the electrical actuator has a 5 to 100 psi water pressure requirement.
	Debris in solenoid	Clean out solenoid of any debris.
	Frozen float ball	Inspect, and if so, float or valve may need to be replaced.
	Float ball is full of water	Check ball for leaks and replace.
Water Constantly Blowing Out Overflow Connection	This can happen on forced draft units due to the positive pressure in the casing section. Overflow connection has not been piped at all or properly	Pipe the overflow with a P-trap to an appropriate drain.
	Incorrect water level	Verify actual operating level versus O&M recommended levels
Water Intermittently Blowing Out Overflow Connection	This is normal	This is normal. The bleed line for the unit is piped to the overflow connection
Cold Water Basin Overflowing	Problem with make-up line.	Refer to Makeup Valve or Electronic Water Level section.
	If multi-cell unit, there may be an elevation problem.	Make sure that multi-cell units are installed level to one another. If they are not, it can cause overflowing in one cell.

Problem	Possible Cause	Remedy
Low Pan Water Level	Electronic Water Level Control	See EWLC Section
	Float Ball not set correctly	Adjust float ball up or down to obtain proper water level. Note: The float ball is set to the operating level at the factory.
Rusting Stainless Steel	Foreign material on surface of SS	Rust spots that show up on the surface of the unit are typically not signs of the base stainless steel material corroding. Often, they are foreign material, such as welding slag, that has collected on the surface of the unit. The rust spots will be located around where there has been welding. These areas may include the coil connections, the cold water basin near the support steel, and around field erected platforms and catwalks. The rust spots can be removed with a good cleaning. EVAPCO recommends using either Naval Jelly or a good stainless steel cleaner, such as Mother's Wax in conjunction with a Scotch-Brite pad. Maintenance of the unit's surface should be done on a regular basis.
Cracking Fluid Cooler Insulation	Cracking paint	Most of the time, it is the paint that is cracking and not the insulation. If the paint is degrading, it should be touched up to maintain the finish on the insulation. It is recommended that maintaining the finish of the insulation paint be a part of the standard maintenance program. If the insulation is cracking, see your local Evapco representative for further guidance.
Electric Water Level Control Not Working	The valve won't open or close	<ol style="list-style-type: none"> 1. Verify that water pressure is above 5psi and below 100psi. 2. Verify wiring with wiring diagram. Check supply voltage. 3. Verify that there is not a blockage in the Y-Strainer 4. Confirm the probes are not dirty. 5. Check Red LED on circuit board. If it is on, the valve should be closed.
		<p>For a 3-Probe Assembly:</p> <p>Simulate "Low Water Condition" - LED OFF After cleaning the probes, lift probe assembly out of the stand pipe. This will simulate a "low water condition". Check the contacts for proper position.</p> <ul style="list-style-type: none"> - The contact between "C" and "NC" should now be closed and water makeup valve should be energized (valve open) <p>Simulate "High Water Condition" - LED ON</p> <ul style="list-style-type: none"> - Connect a jumper wire between the longest probe and the shortest probe. The contact between "C" and "NC" should now be open and the water makeup valve should be de-energized (valve closed)

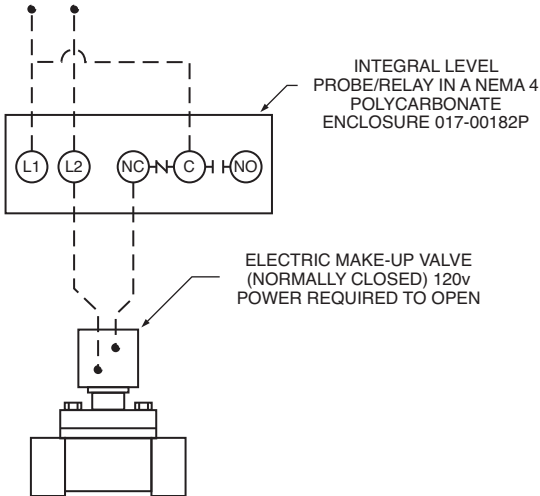

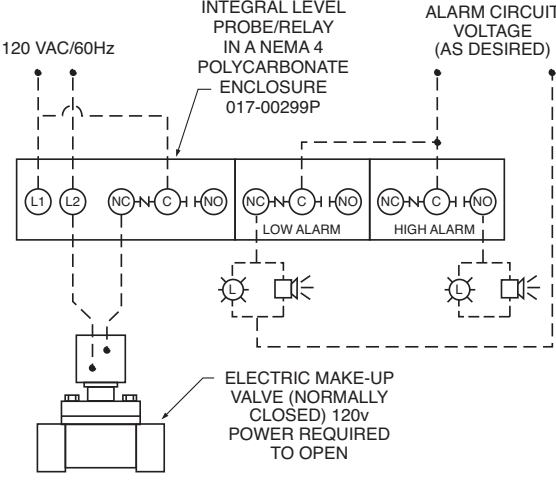
Problem	Possible Cause	Remedy
<p>Electric Water Level Control Not Working</p> 		<p>For a 5-Probe Assembly:</p> <p>Simulate "Low Water Condition" After cleaning the probes, lift probe assembly out of the stand pipe. This will simulate a "low water condition". Check the contacts for proper position.</p> <ul style="list-style-type: none"> - Differential Contacts: C to NC - closed - Water make-up valve energized - LED = OFF - High Alarm Contacts: C to NO - open - High alarm circuit de-energized - LED = OFF - Low Alarm Contacts: C to NC - closed - Low alarm circuit energized - LED = OFF <p>Simulate "High Water Condition" Connect a jumper wire between the longest probe (ground) and all other probes (high limit, high alarm, and low alarm). Check the contacts for proper position.</p> <ul style="list-style-type: none"> - Differential Contacts: C to NC - open - Water make-up valve de-energized - LED = ON - High Alarm Contacts: C to NO - closed - High alarm circuit energized - LED = ON - Low Alarm Contacts: C to NC - open - Low alarm circuit de-energized - LED = ON

Replacement Parts

EVAPCO has replacement parts available for immediate shipment. Most orders ship within 24 hours from time of order!

The following pages contain exploded view drawings of all current Evapco closed circuit coolers and condensers. Please use these drawings to help identify the major parts of your unit. To order replacement parts, please contact your local EVAPCO representative or Mr. GoodTower Service Center. The EVAPCO representative contact information is located on the unit's nameplate or can be found by visiting either www.evapco.com or www.mrgoodtower.com.

Additionally, your local EVAPCO representative or Mr. GoodTower Service Center can provide FREE unit inspections to help ensure your equipment operates at peak performance regardless of the original manufacturer!

ATWB & eco-ATW 3' Wide Units

FAN & COIL CASING SECTION

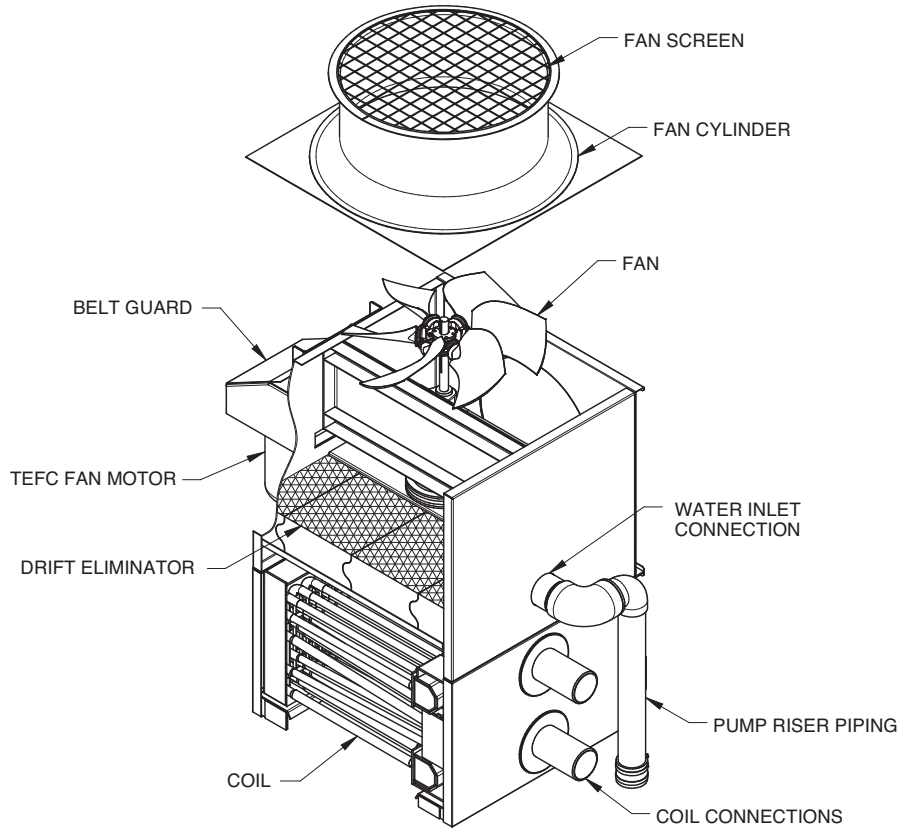

PAN SECTION

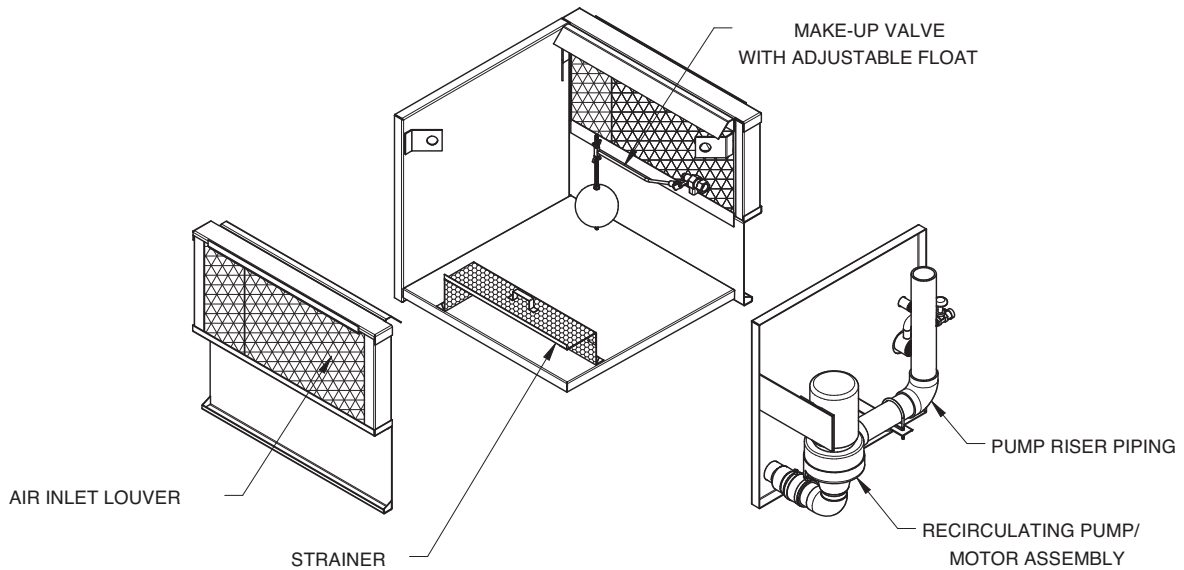

ATC-E/ATWB/eco-ATW 4'x4' & 4'x6' Wide Units

FAN & COIL CASING SECTION

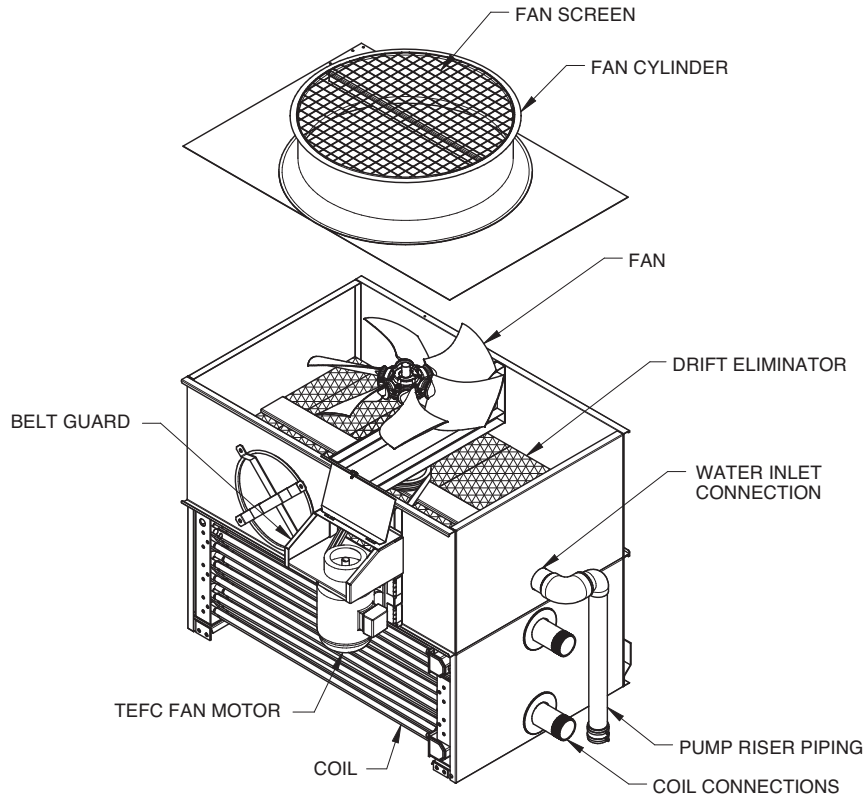

PAN SECTION

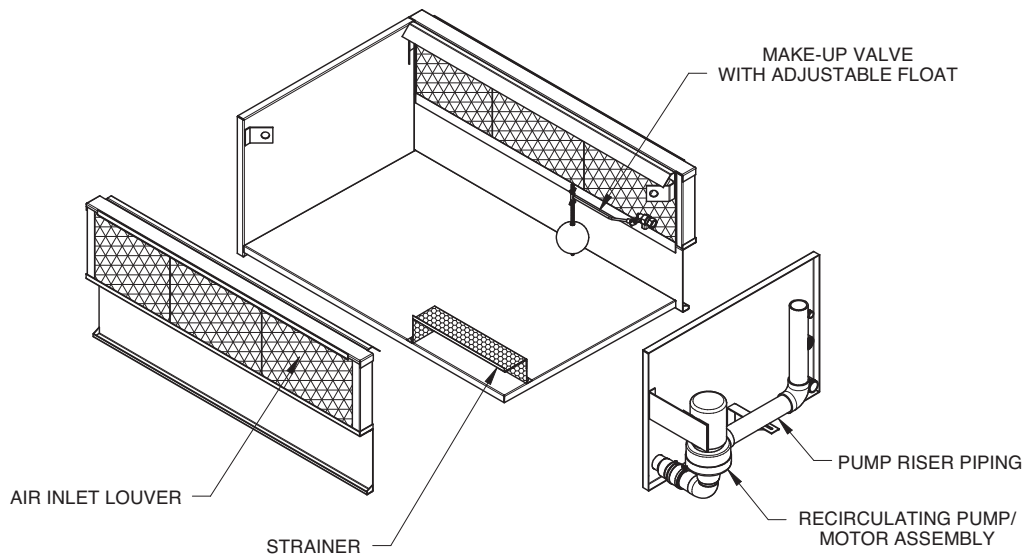

ATC-E/ATWB/eco-ATW 4'x9' & 4'x12' Wide Units

FAN & COIL CASING SECTION

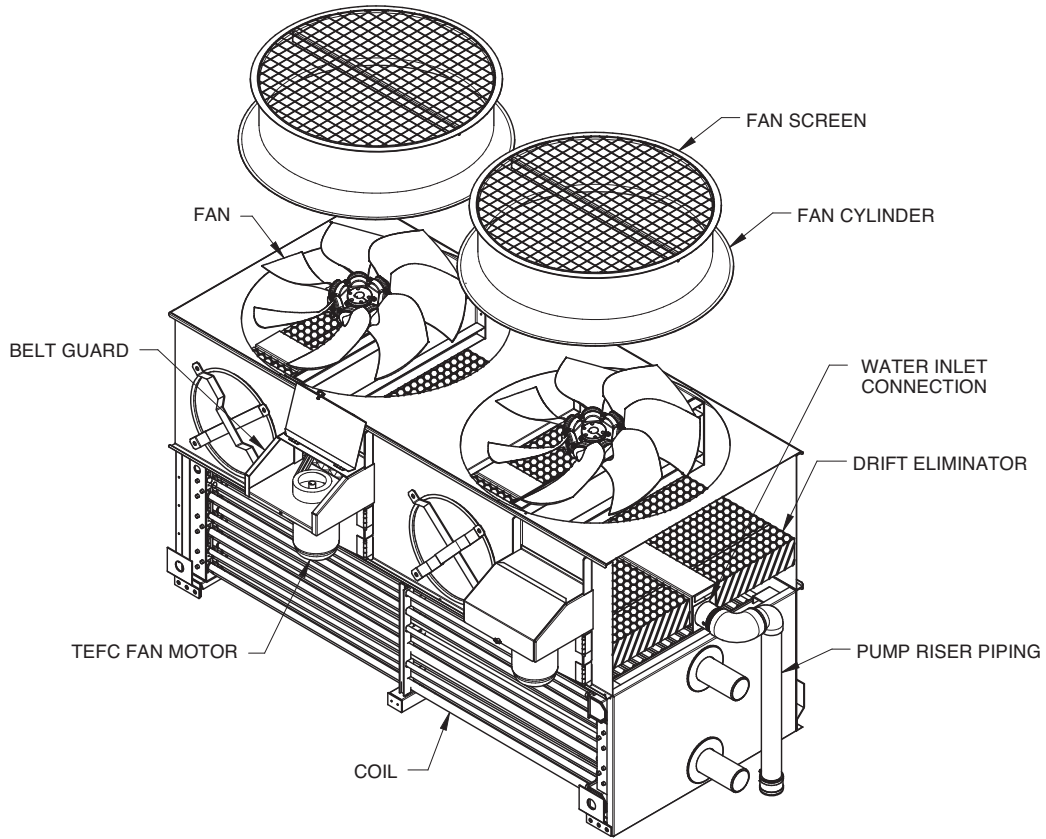

PAN SECTION

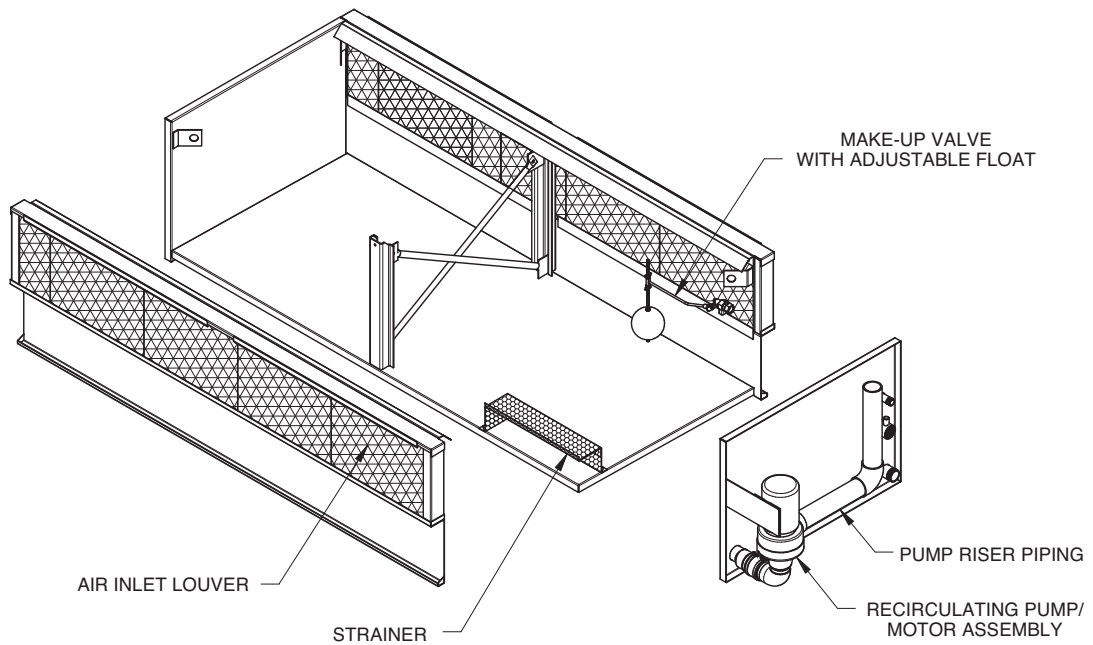

ATC-E/ATWB/eco-ATC/eco-ATW 8' & 8.5' Wide Units

FAN & COIL CASING SECTION

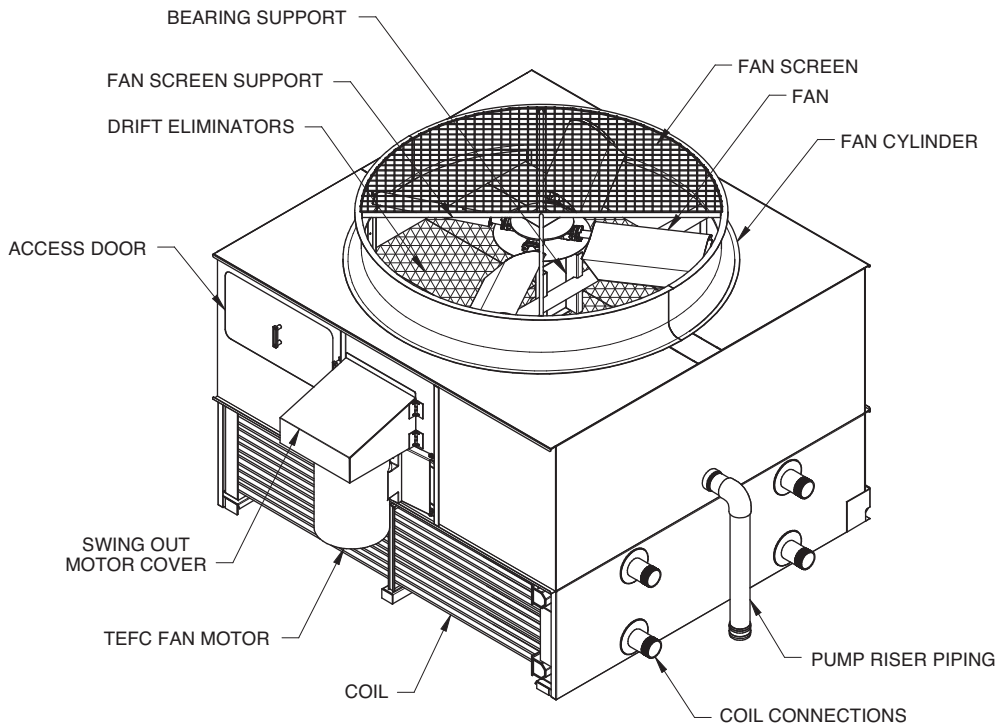

PAN SECTION

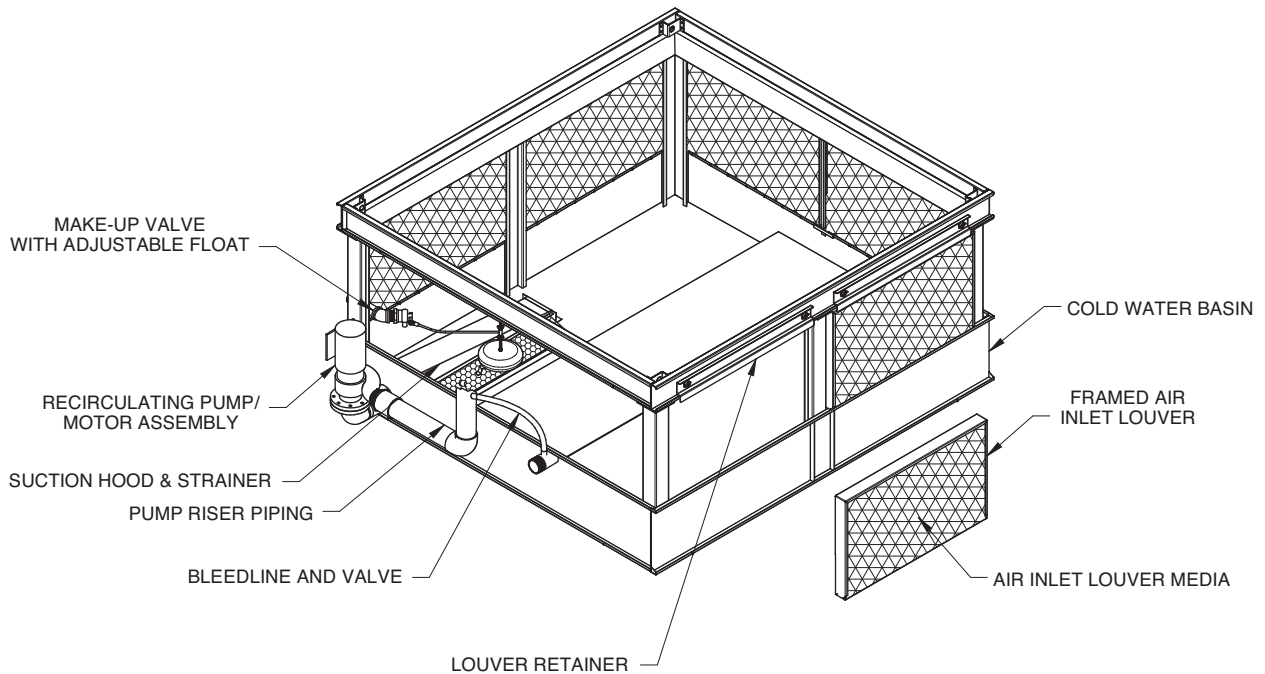

ATC-E/ATWB/eco-ATC/eco-ATW 10' & 12' Wide Units

FAN & COIL CASING SECTION

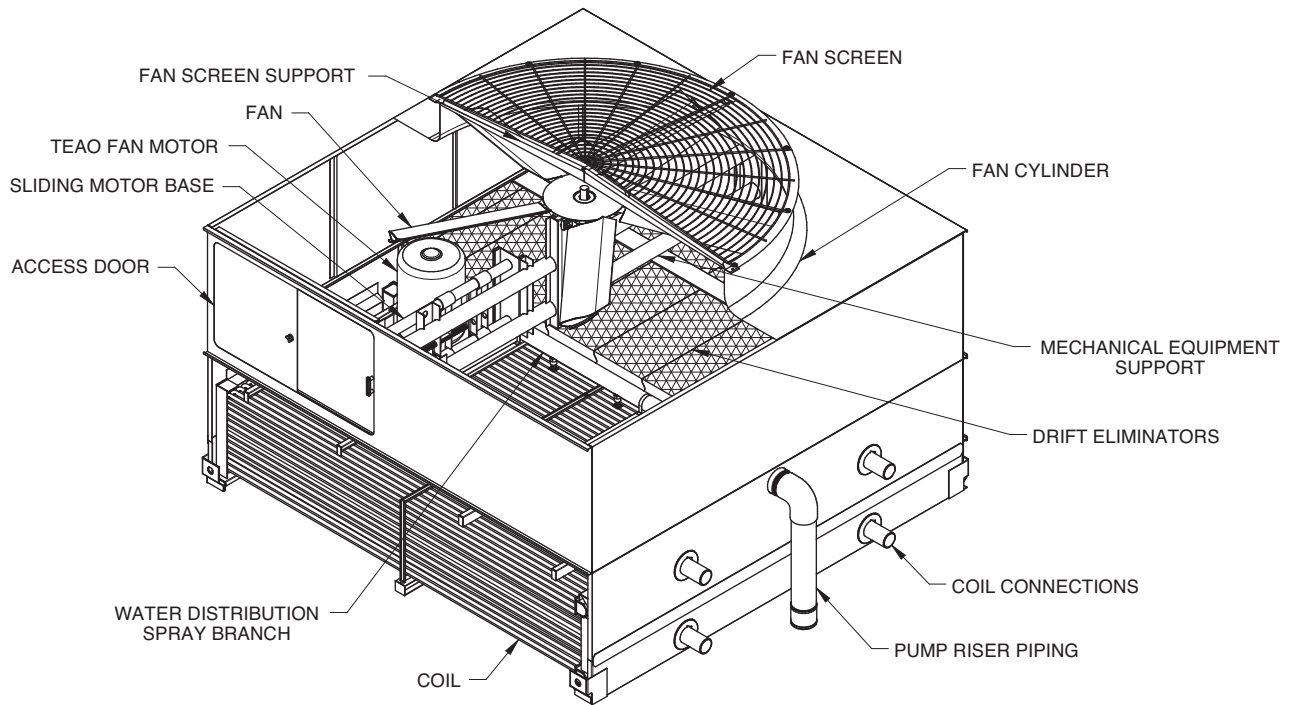

PAN SECTION

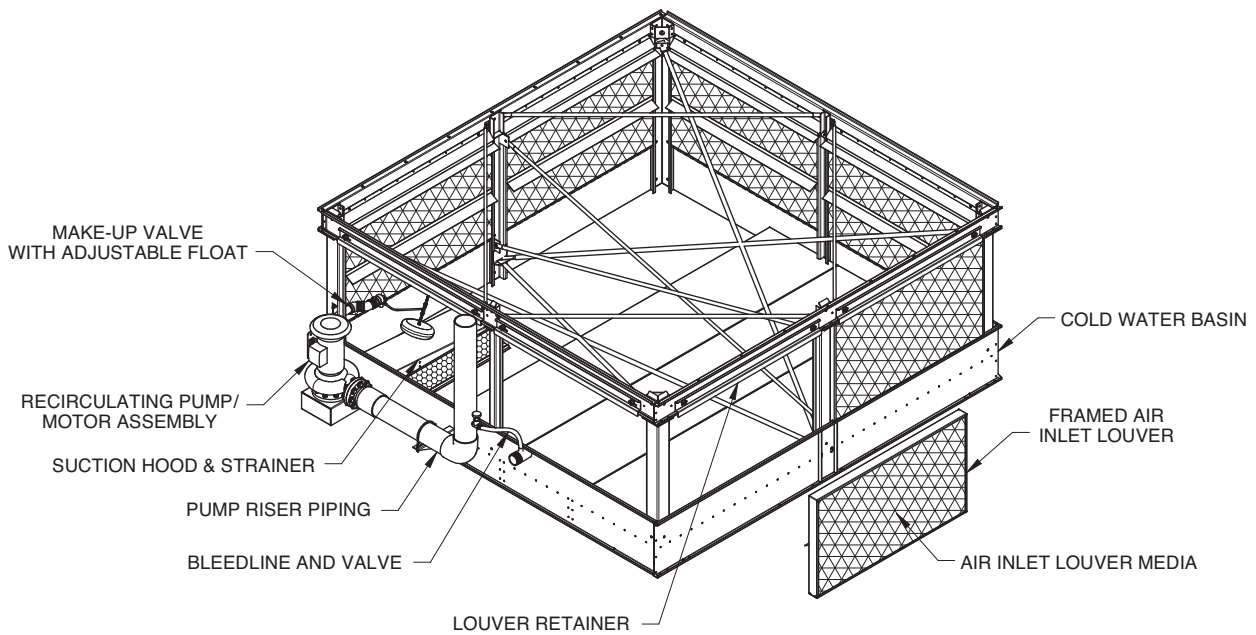

MTW/C 4' (4' x 6' & 4' x 9') Wide Units

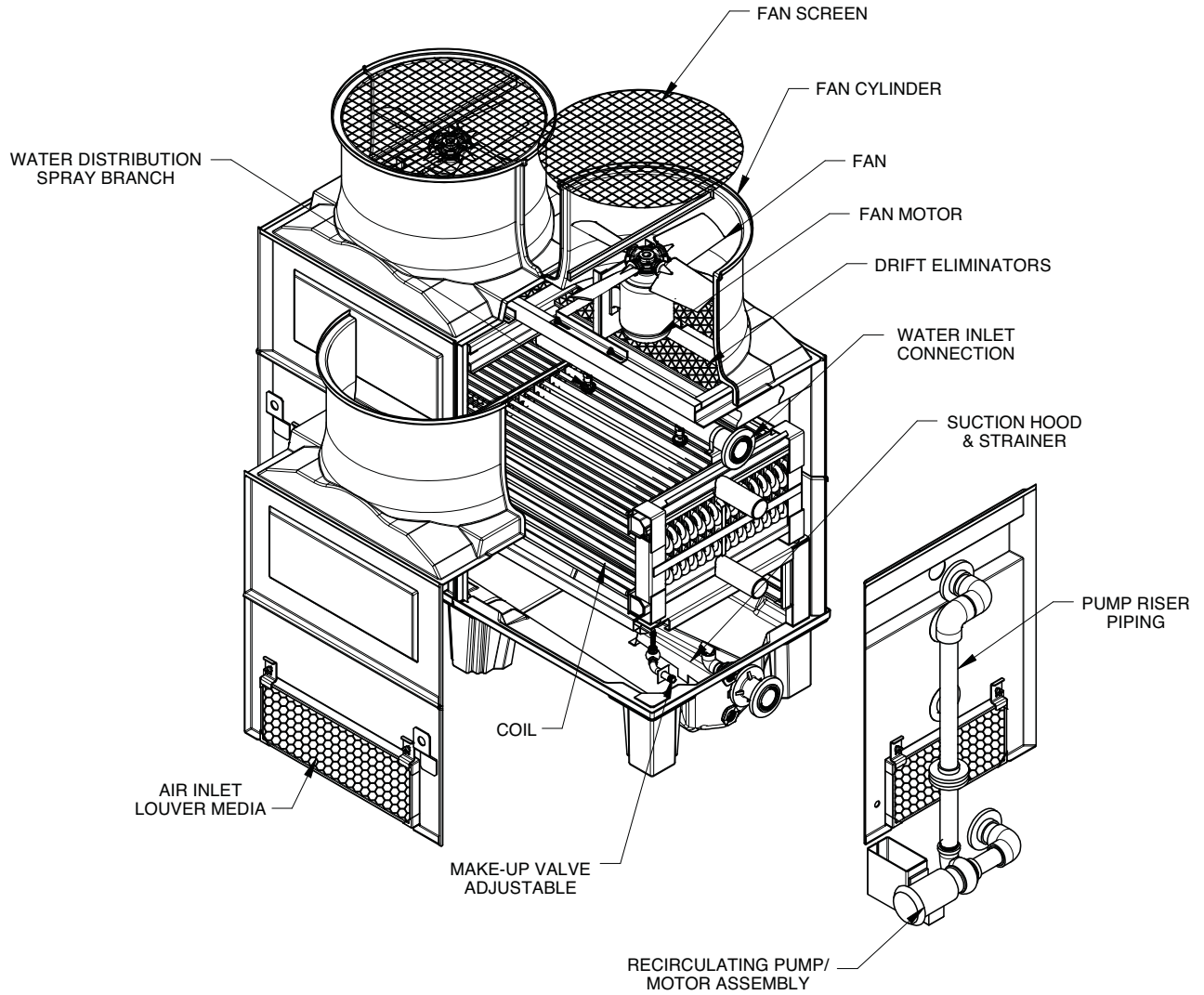

MTW/C 8' Wide Units

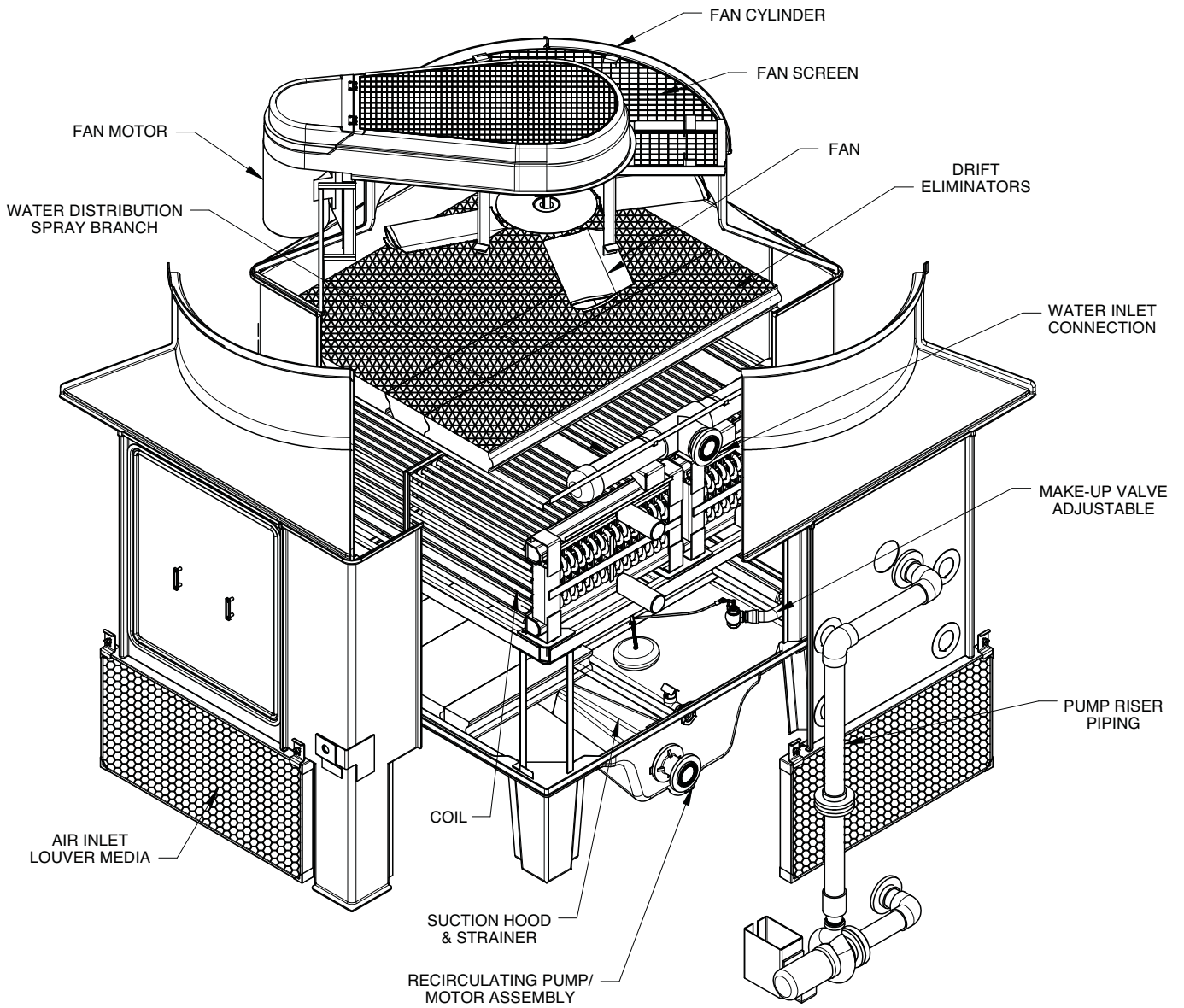

MTW/C 10' Wide Units

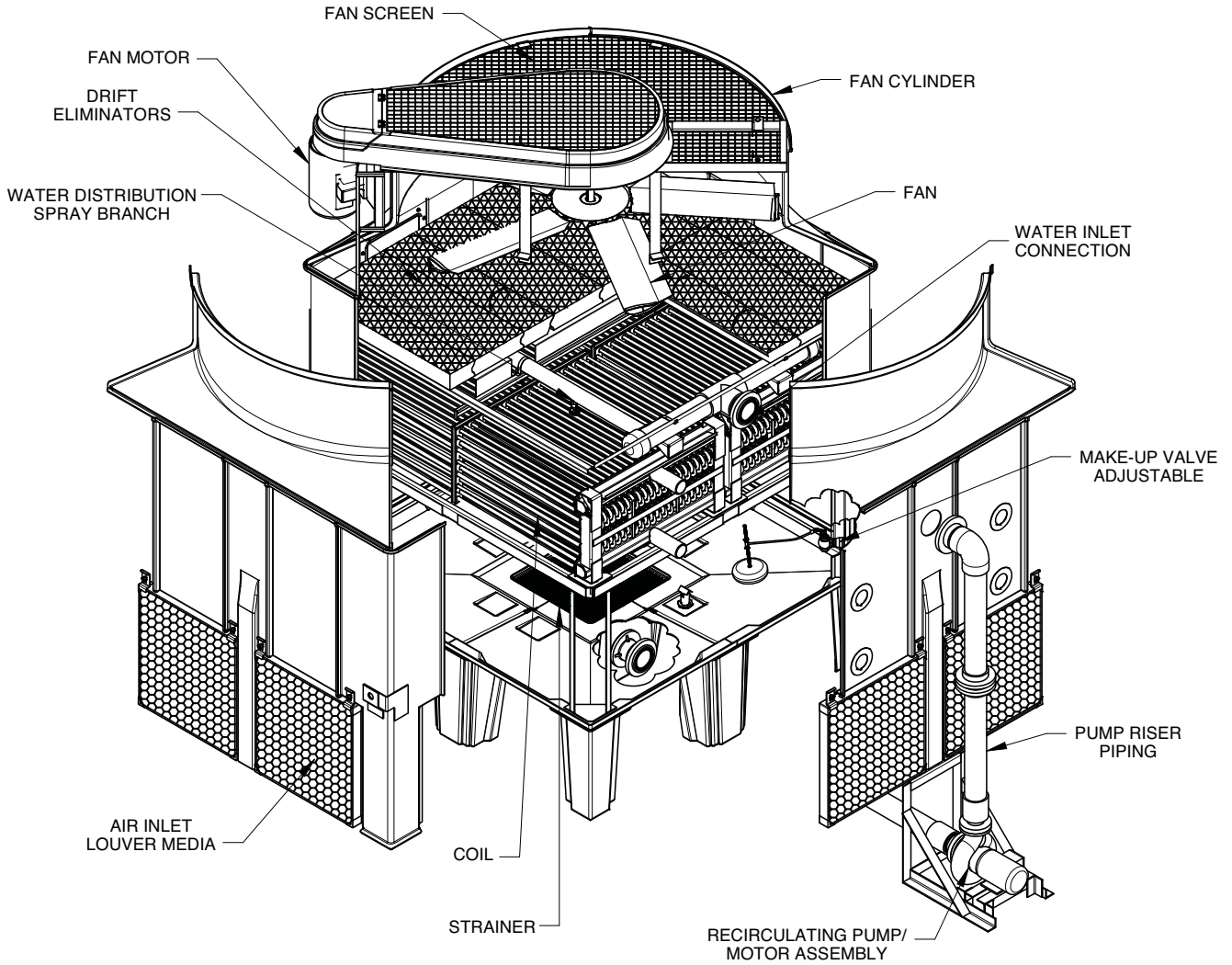

MTW/C 12' Wide Units

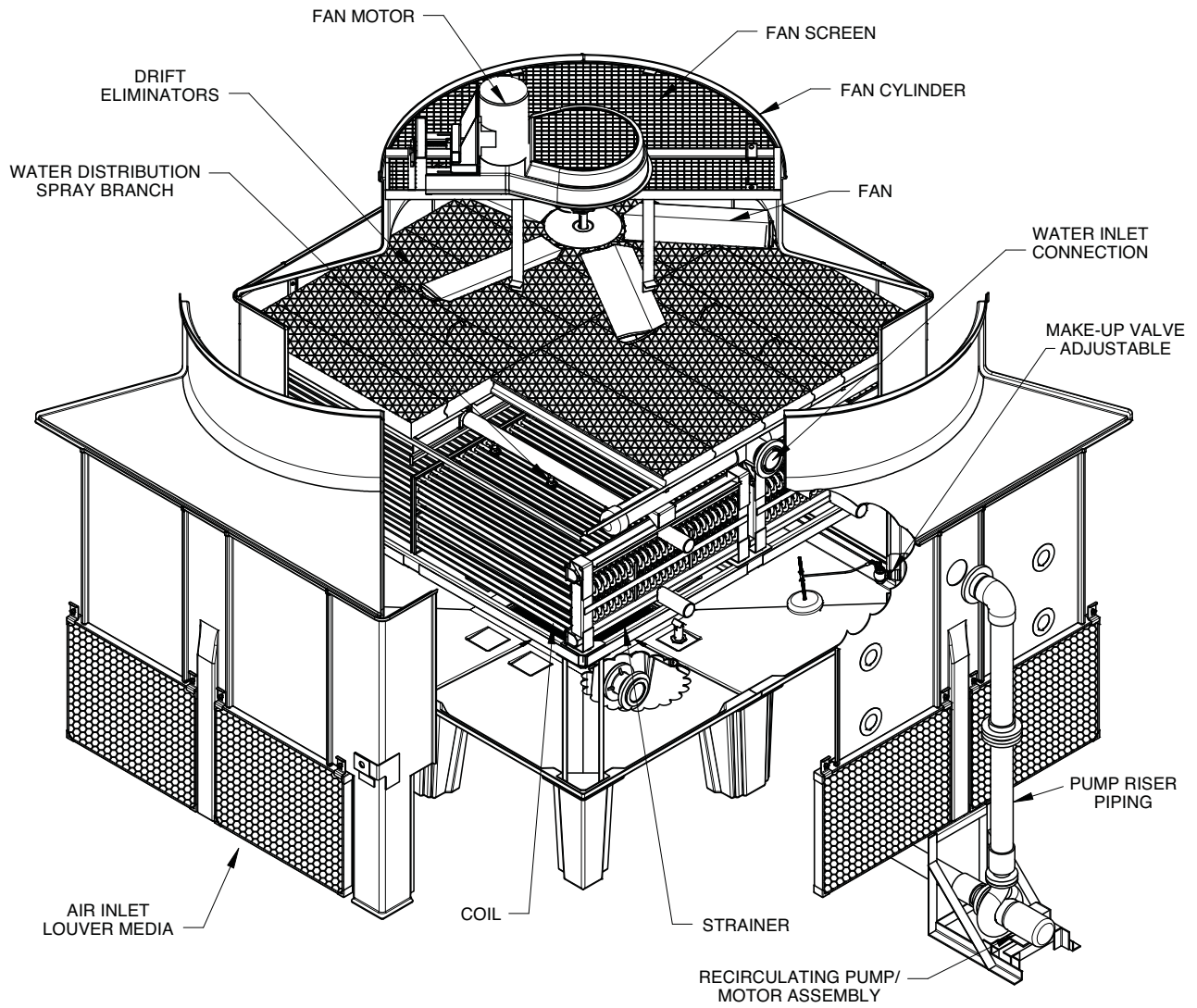

eco-ATWE 8.5' Wide Units

FAN & COIL CASING SECTION

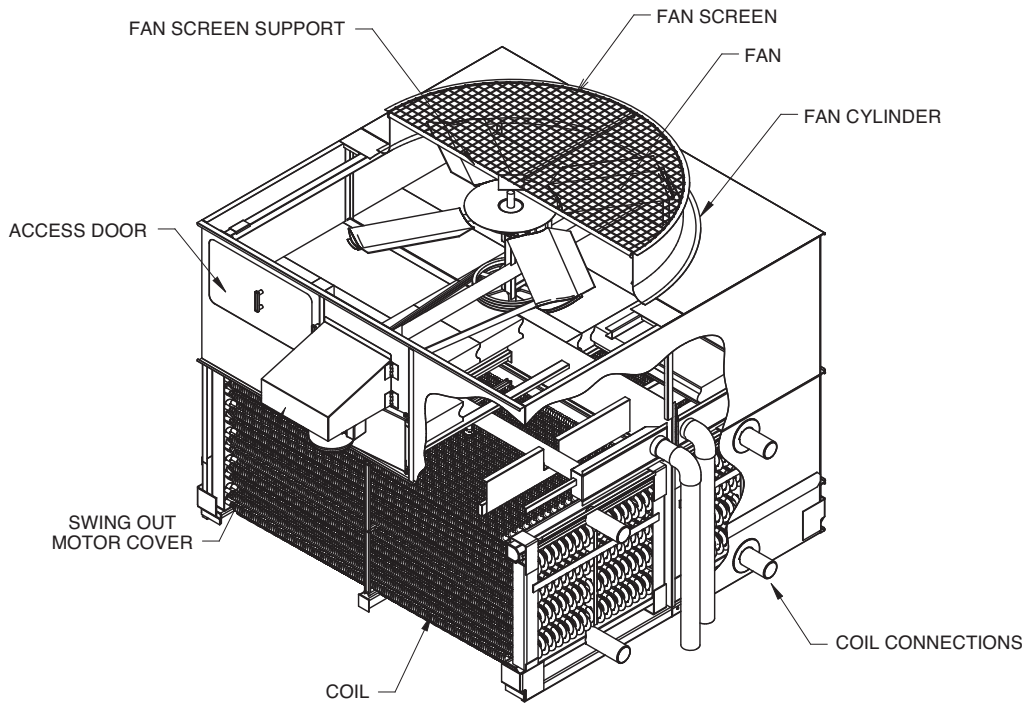

PAN SECTION

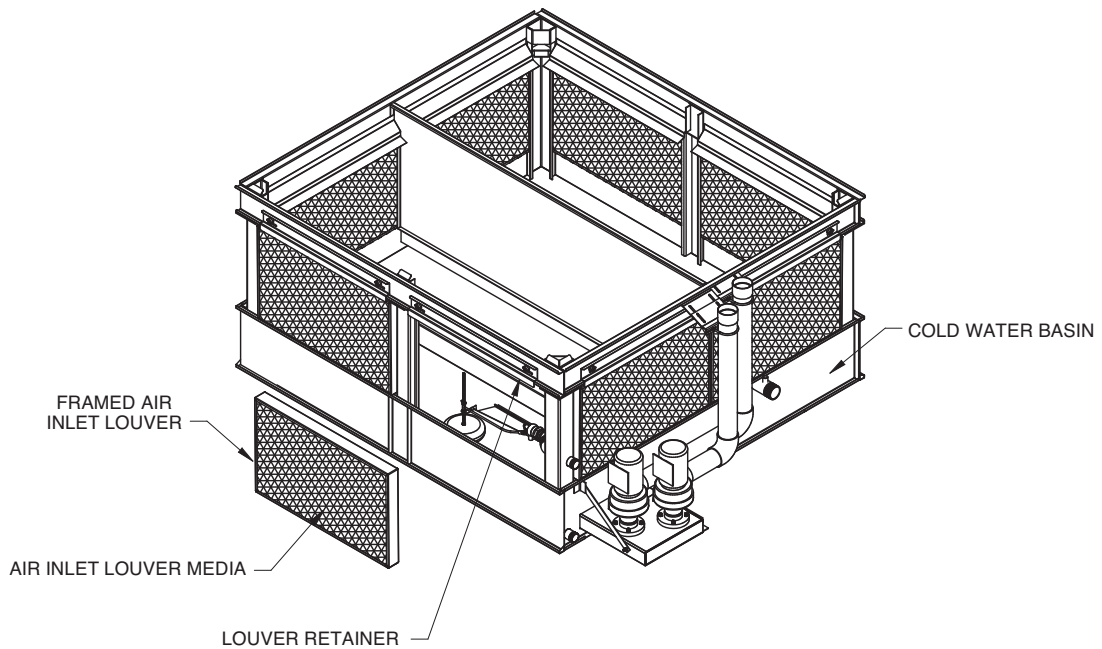

eco-ATWE 10' Wide Units

FAN & COIL CASING SECTION

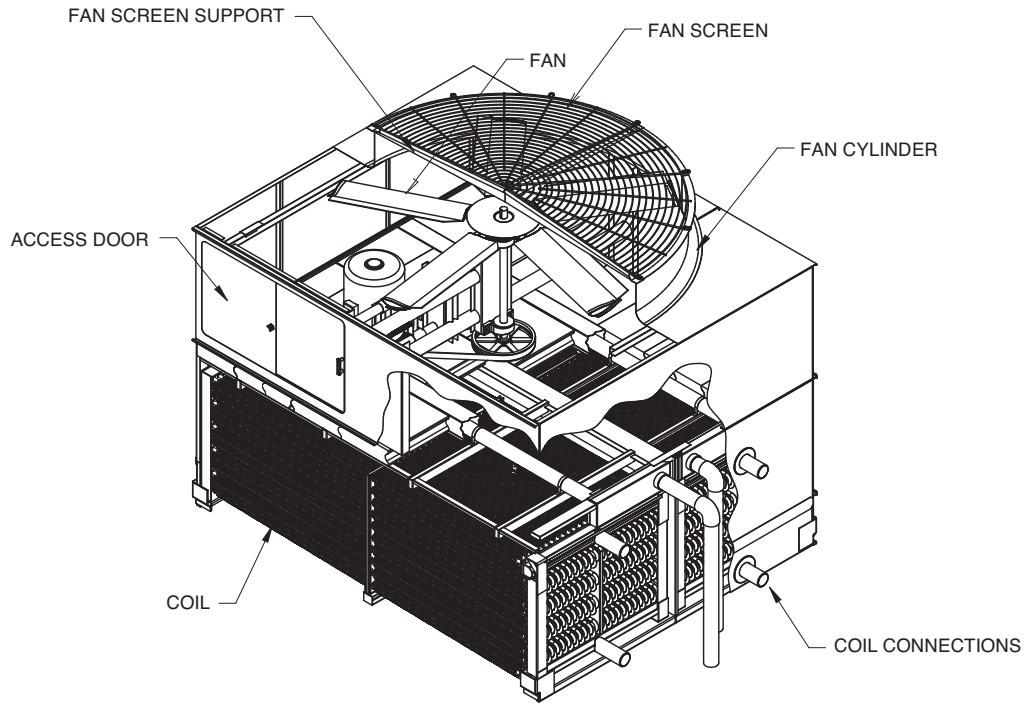

PAN SECTION

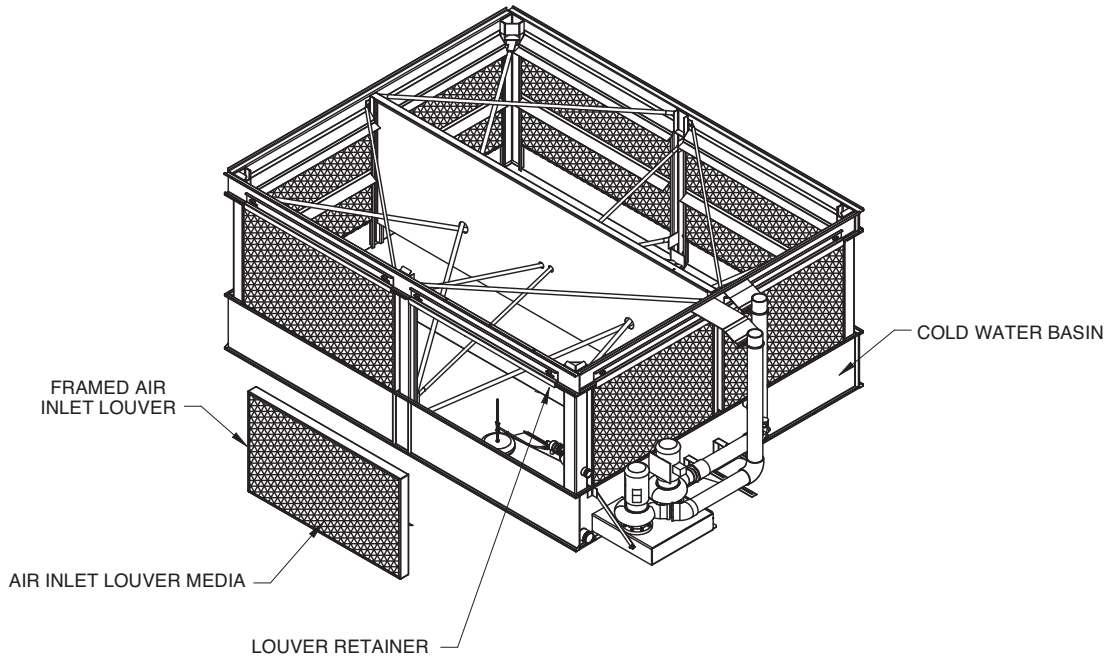

ESWA 12' Wide Units

FAN & FILL CASING SECTION

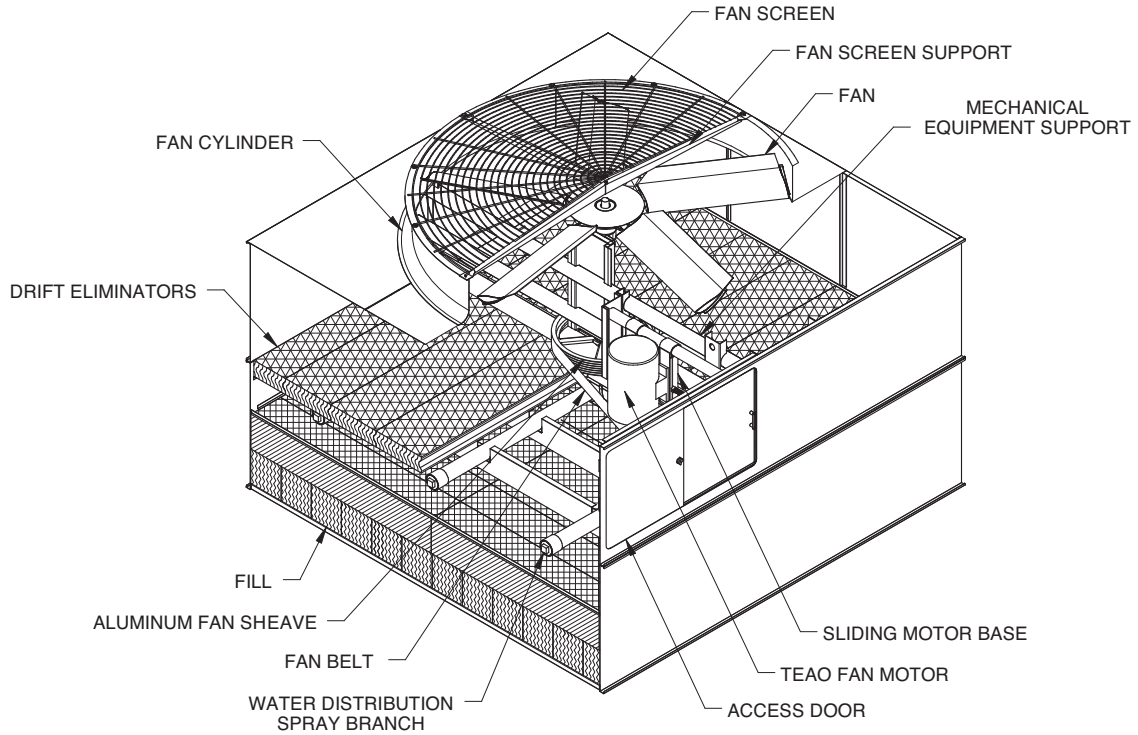

PAN SECTION

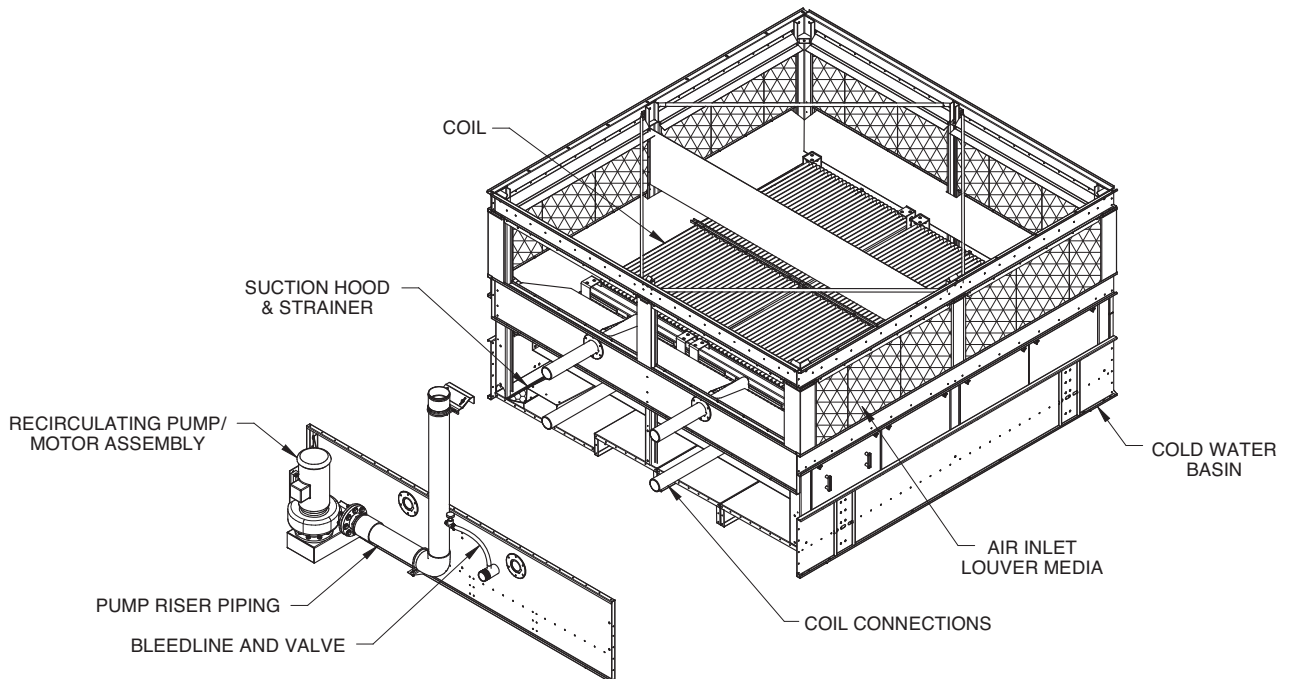

ESWA 14' Wide Units

FAN & FILL CASING SECTION

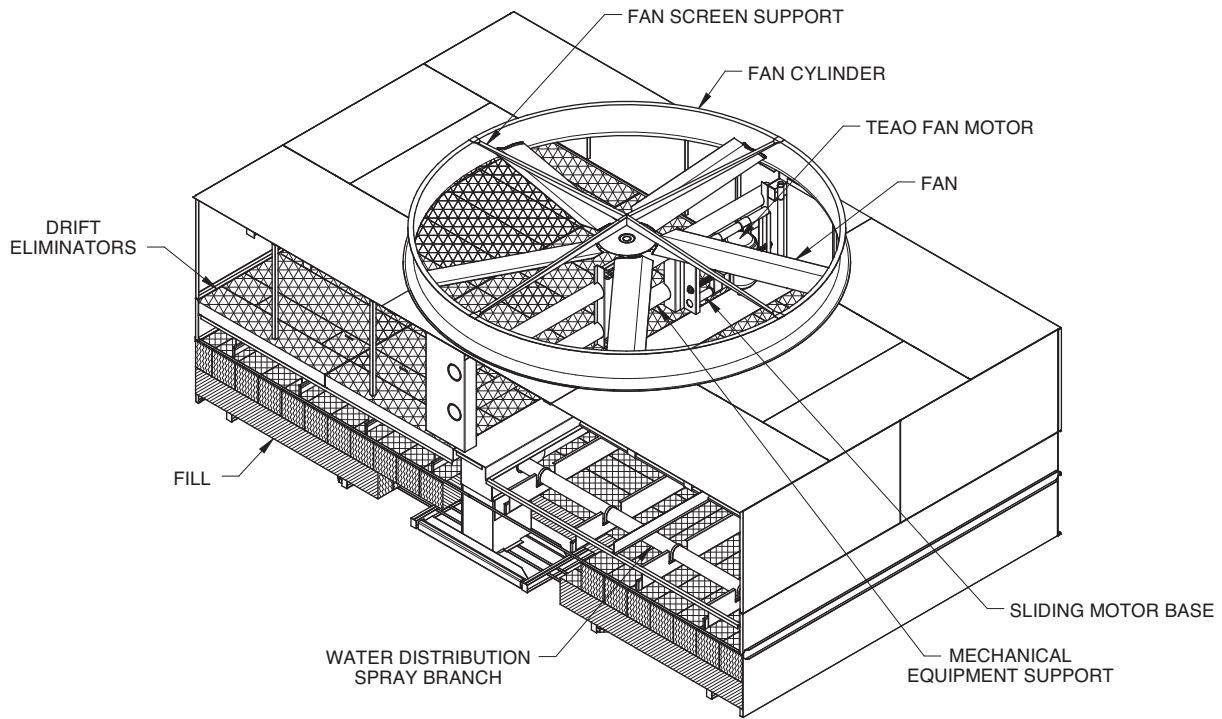

PAN SECTION

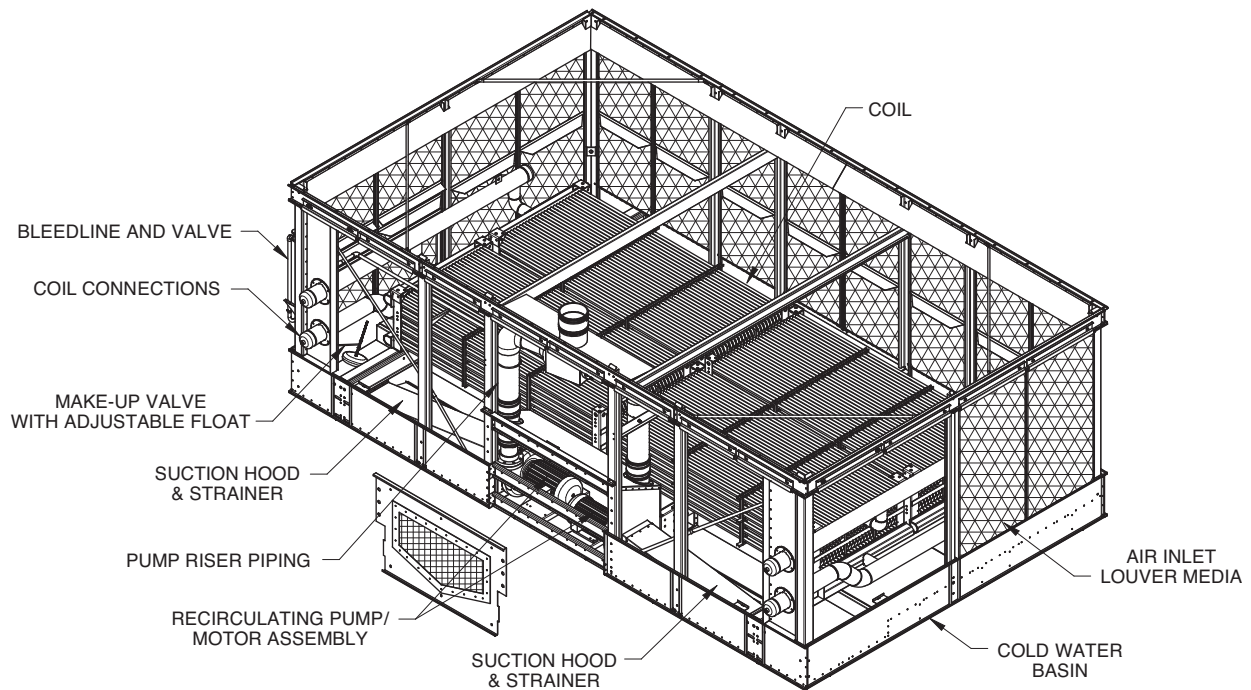

eco-ATWB-H 8.5' Wide Units

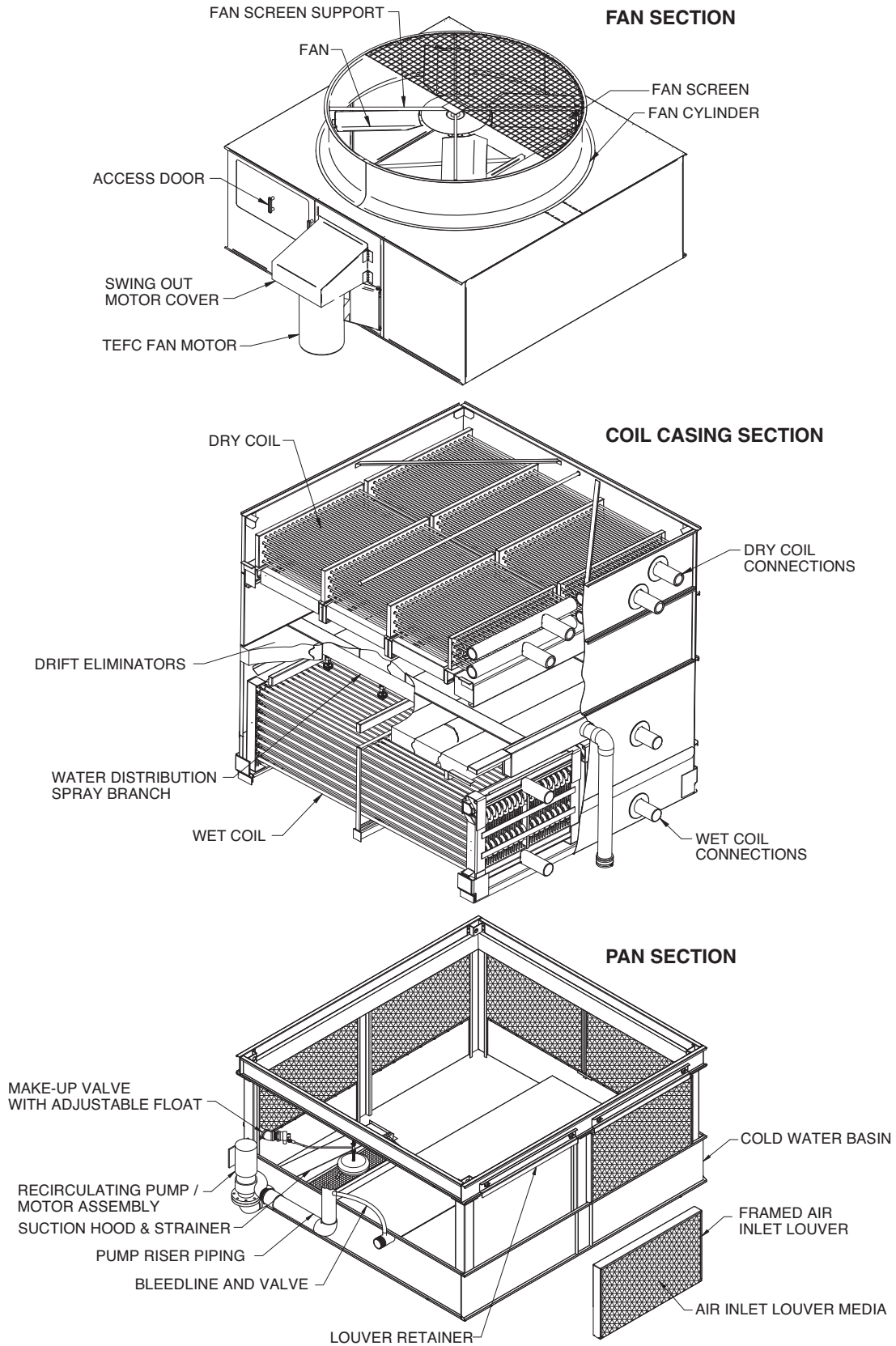

eco-ATWB-H 10' and 12' Wide Units

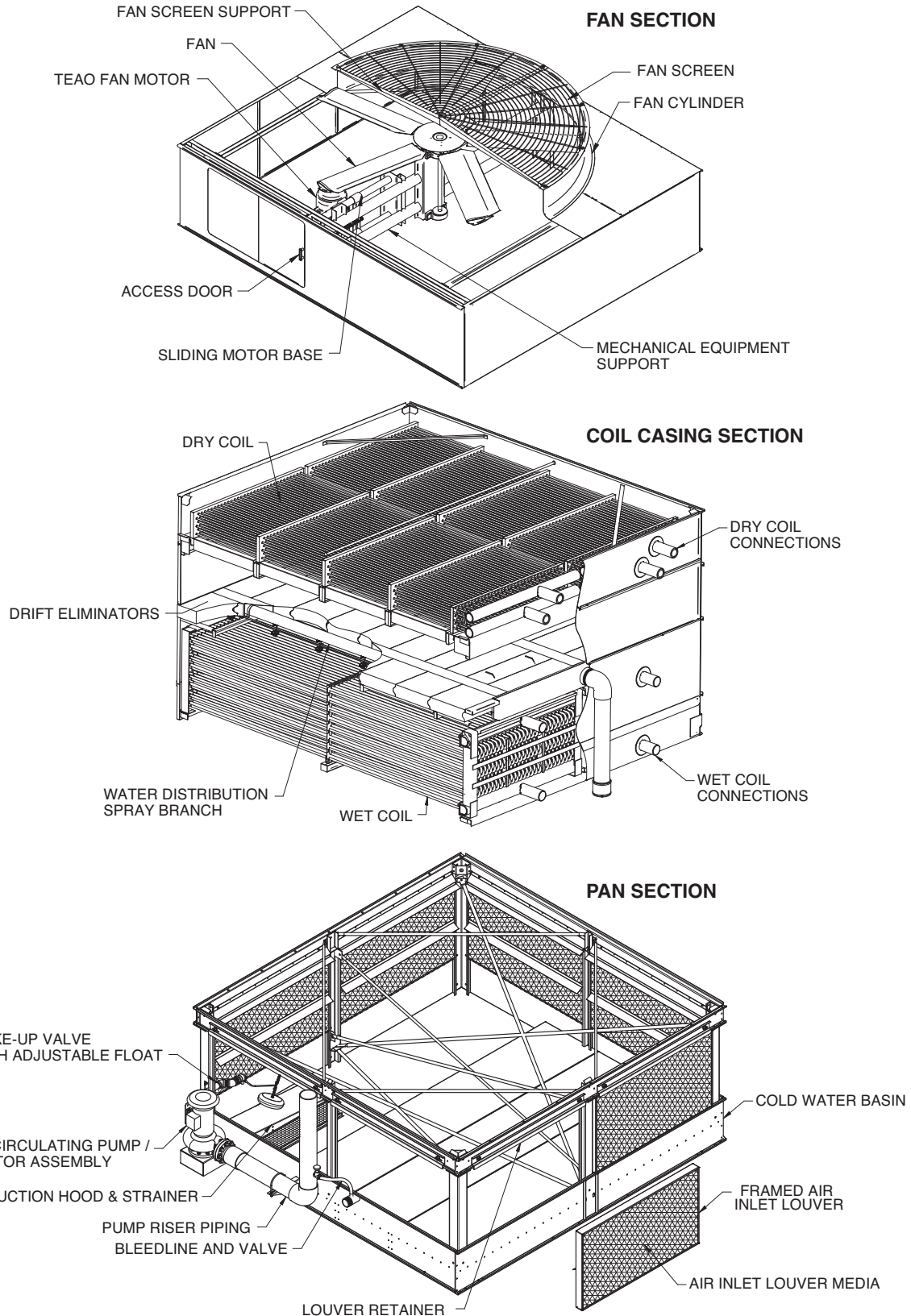

ESWB 8.5' Wide Units

FAN & FILL CASING SECTION

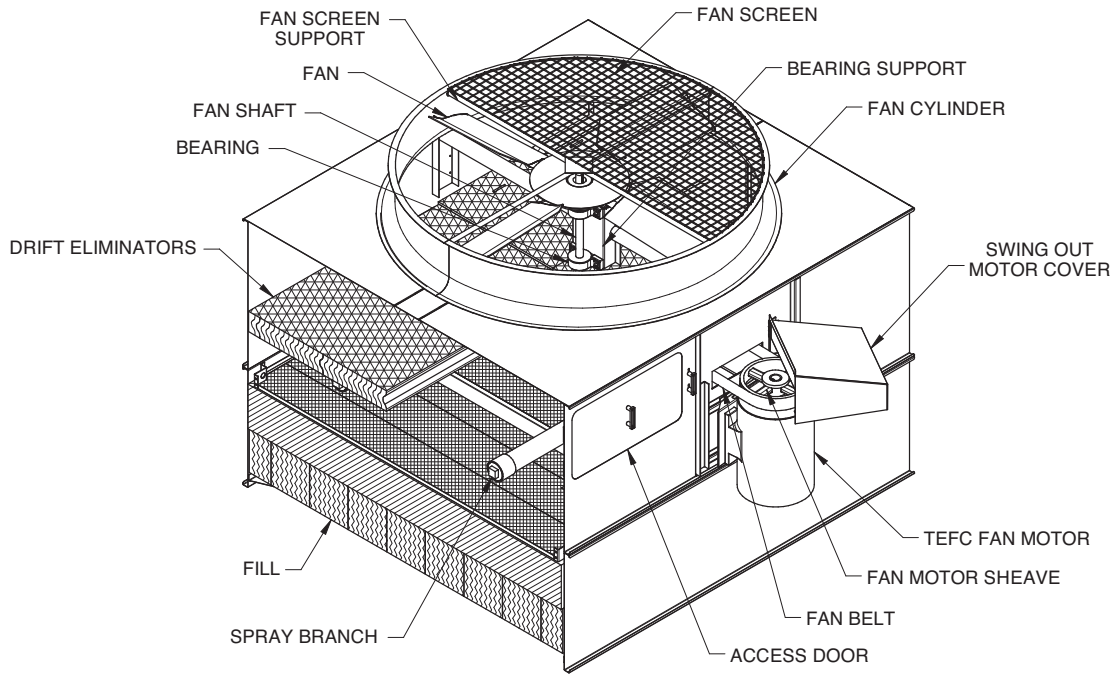

PAN SECTION

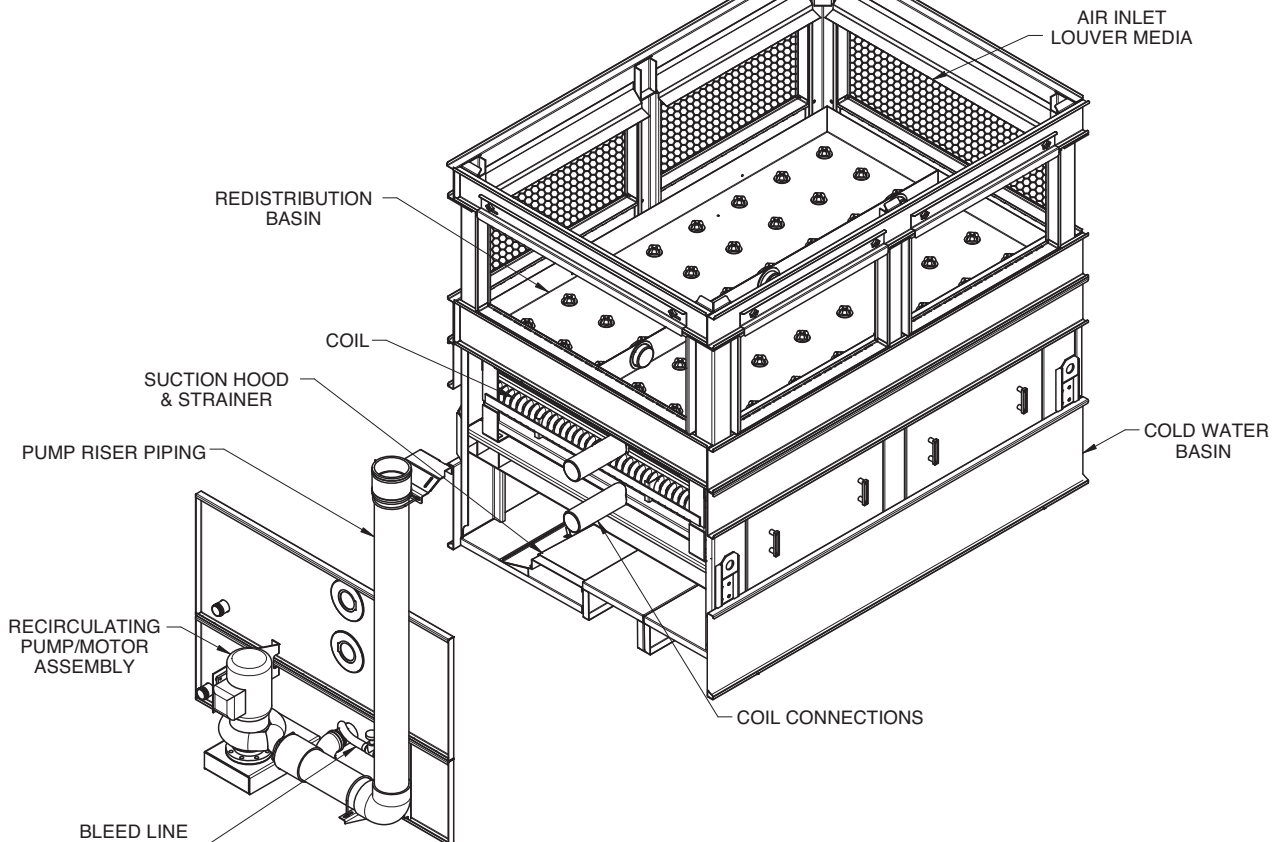

ESWB 12' Wide Units

FAN & FILL CASING SECTION

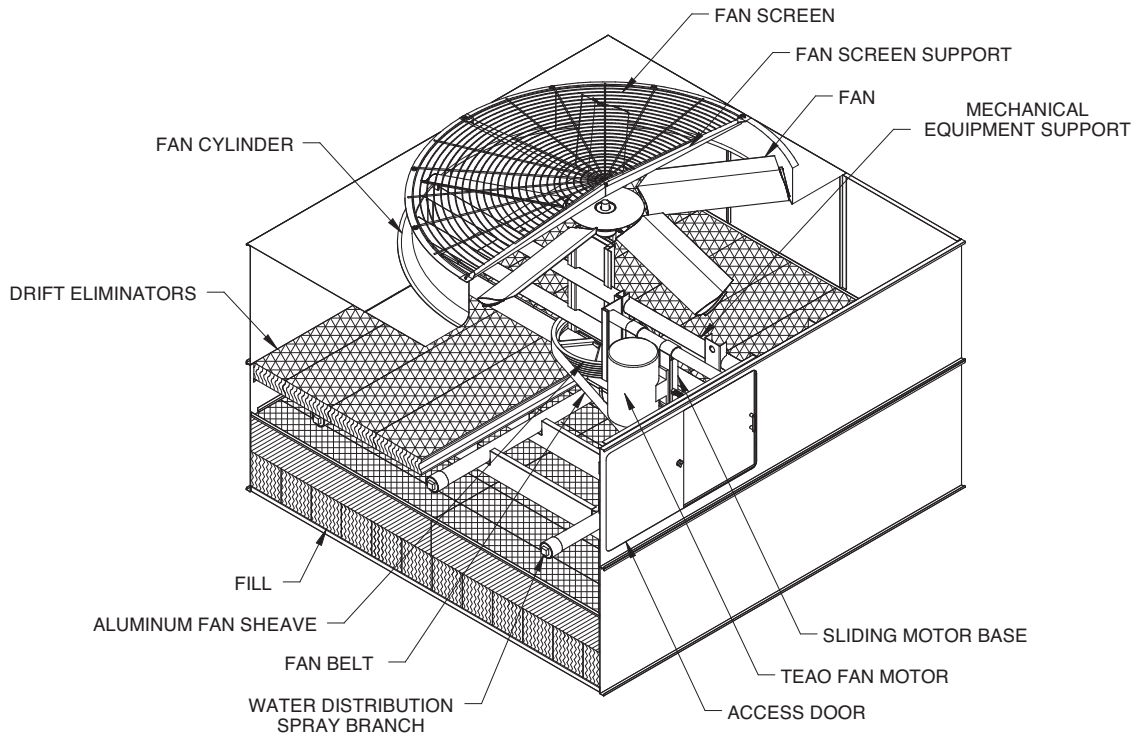

PAN SECTION

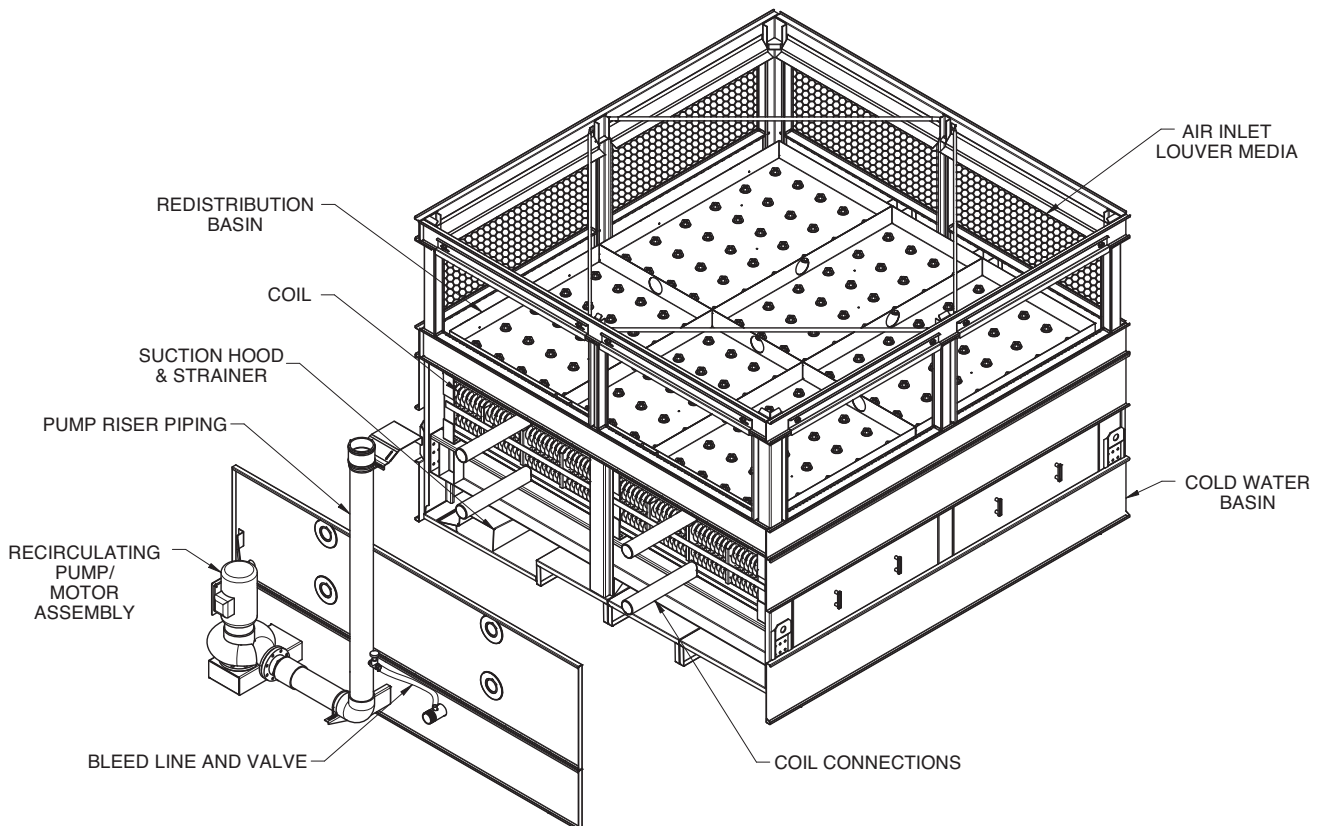

LSC-E/LSWE/eco-LSWE 4' Wide Units

COIL CASING SECTION

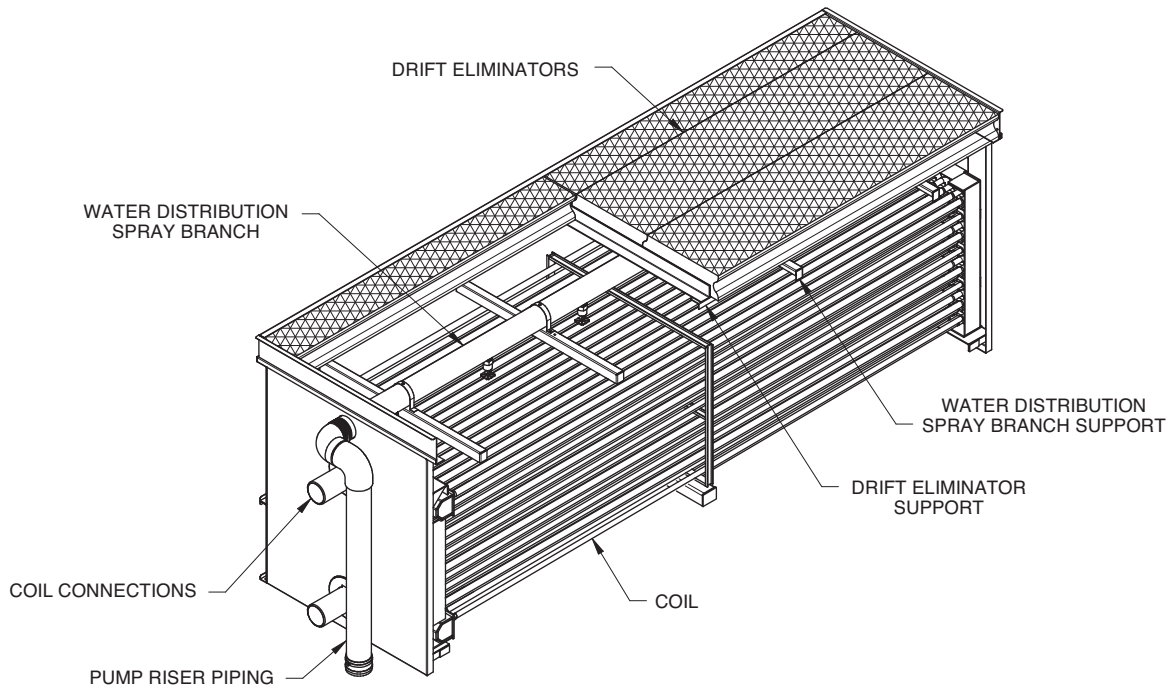

PAN SECTION

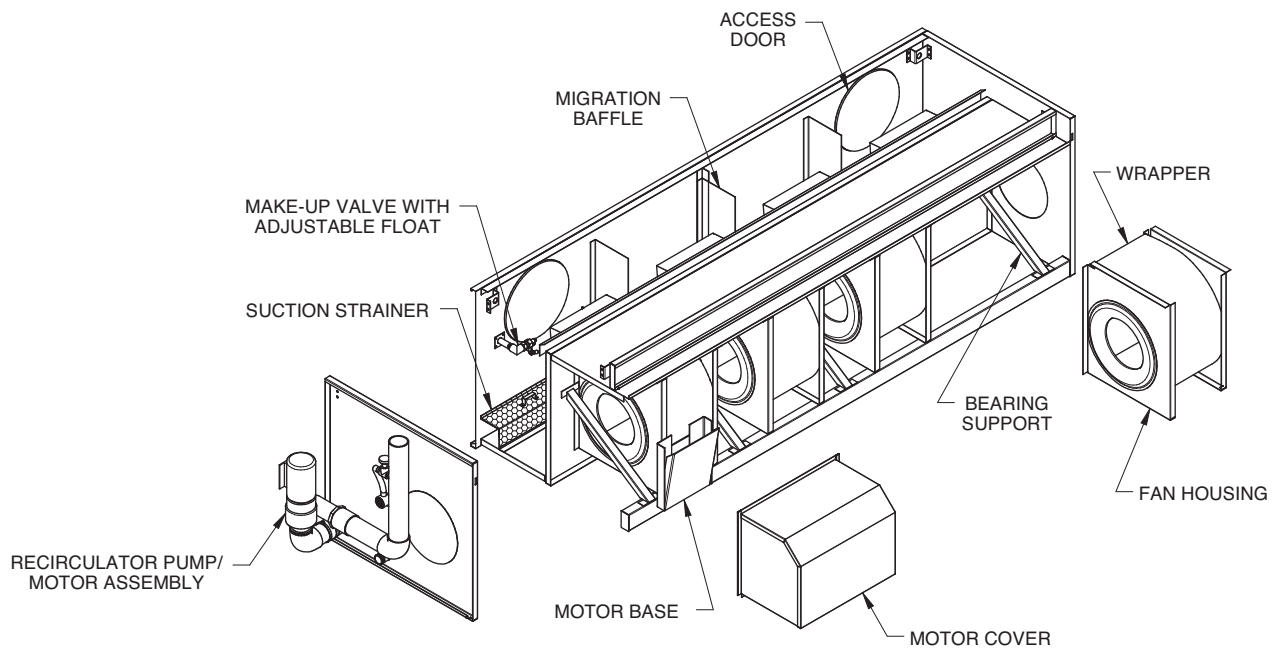

LSC-E/LSWE/eco-LSWE 5' Wide Units

COIL CASING SECTION

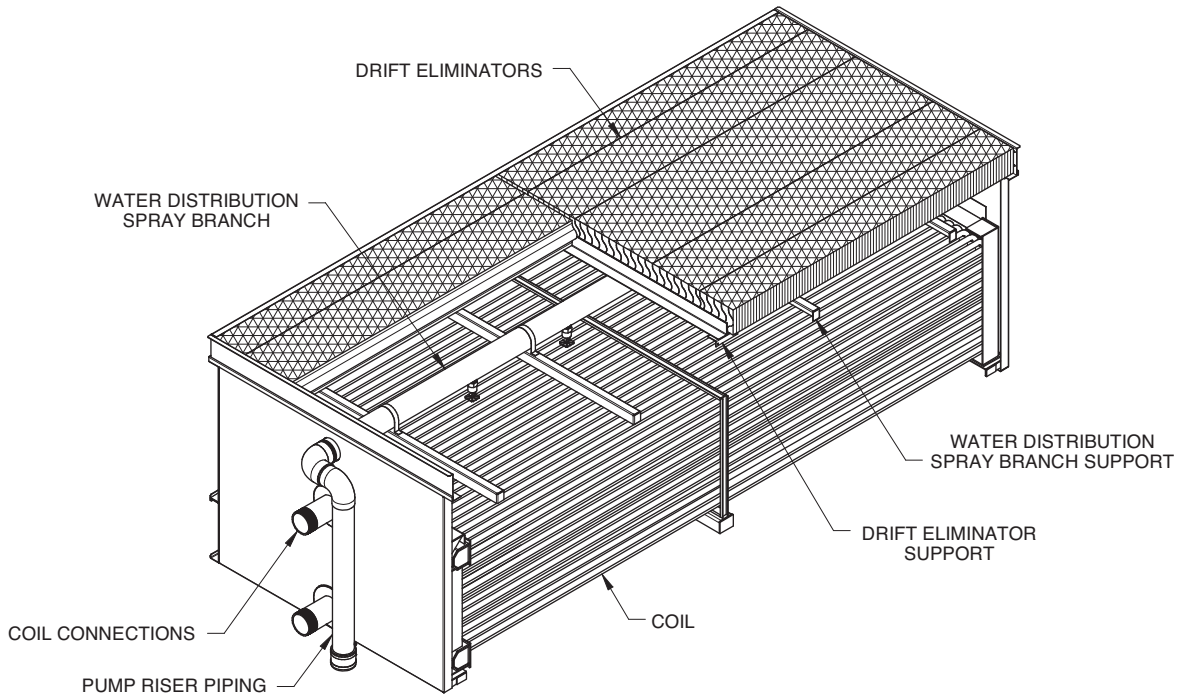

PAN SECTION

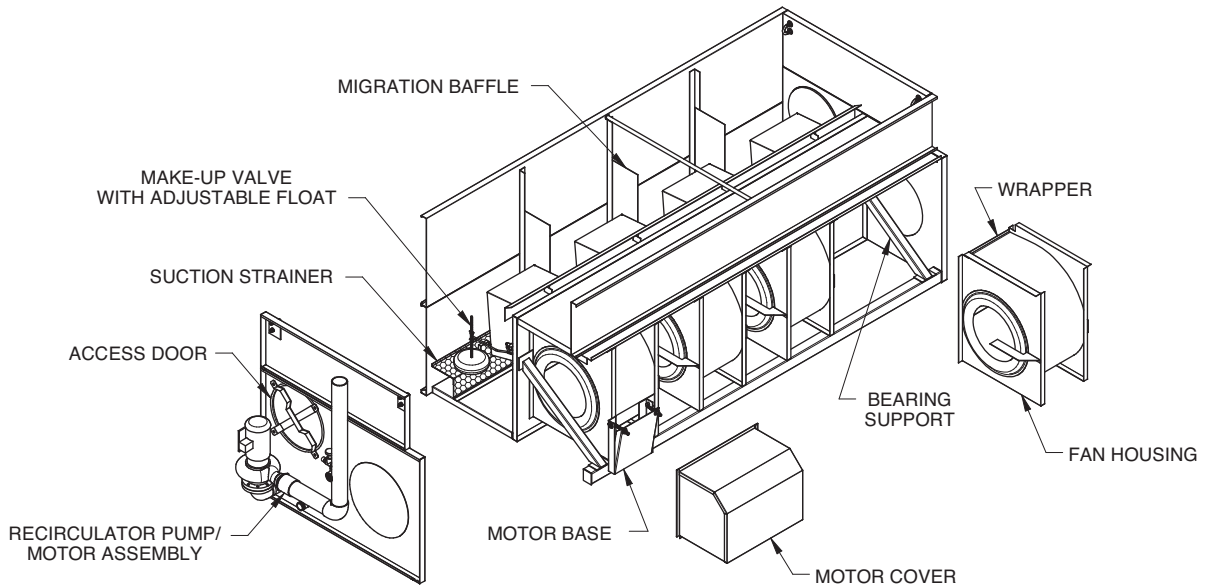

LSC-E/LSWE/eco-LSWE 8' Wide Units (Single Side Fans)

COIL CASING SECTION

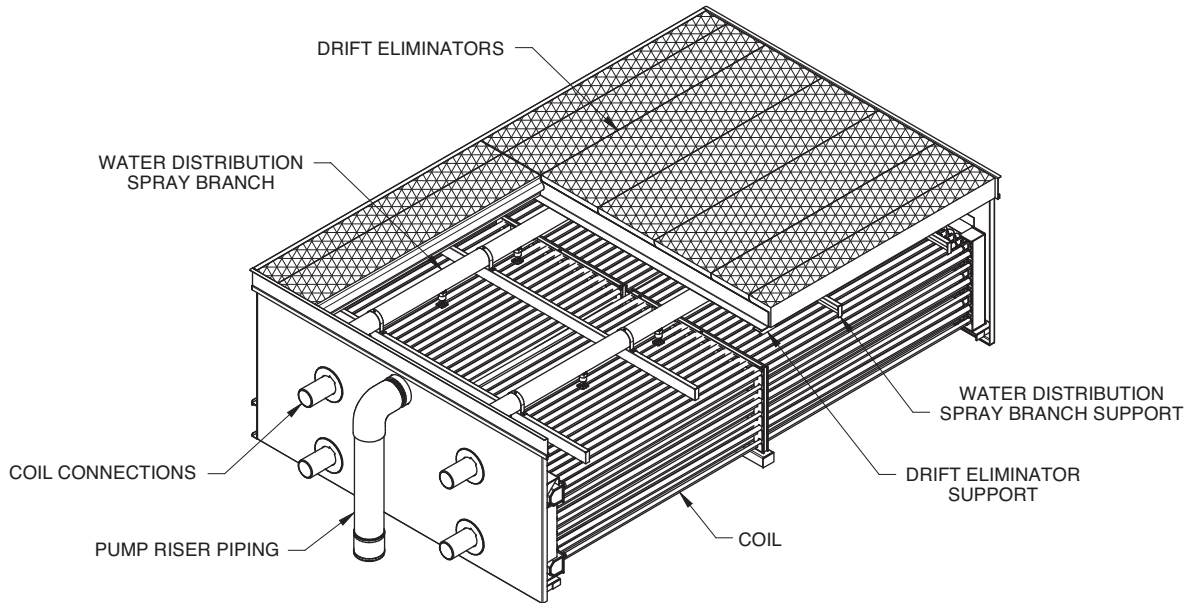

PAN SECTION

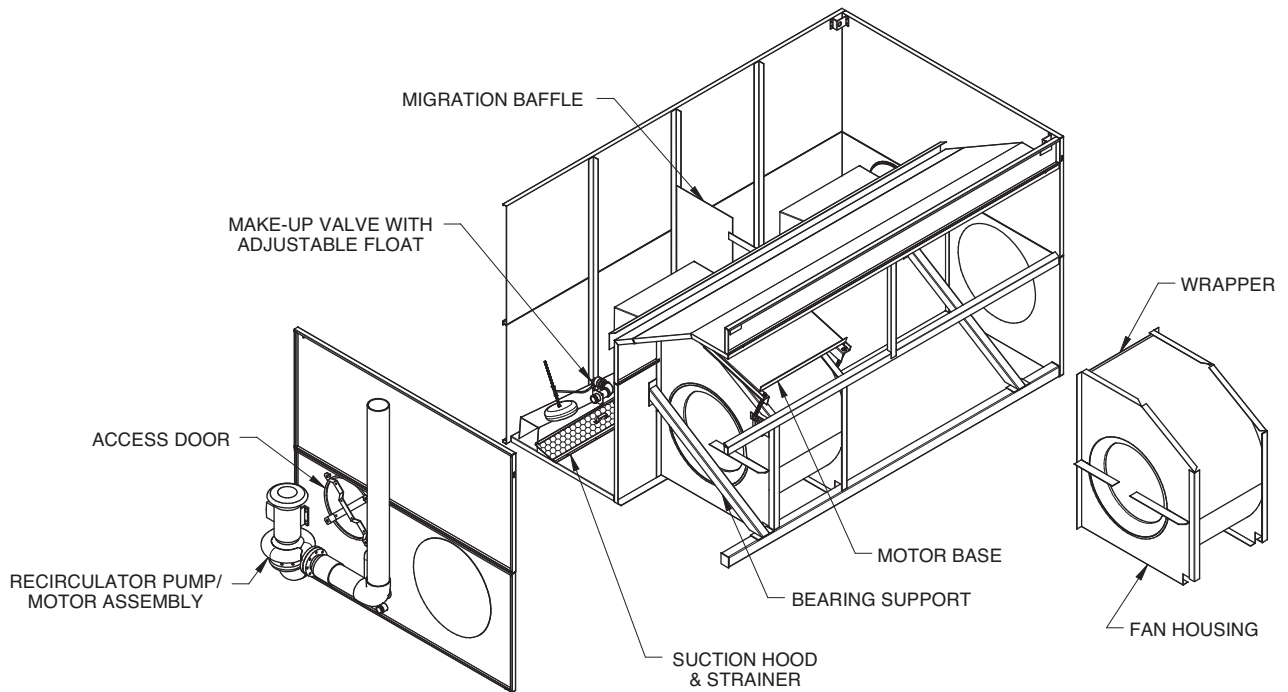

LSC-E/LSWE/eco-LSWE 10' Wide Units

COIL CASING SECTION

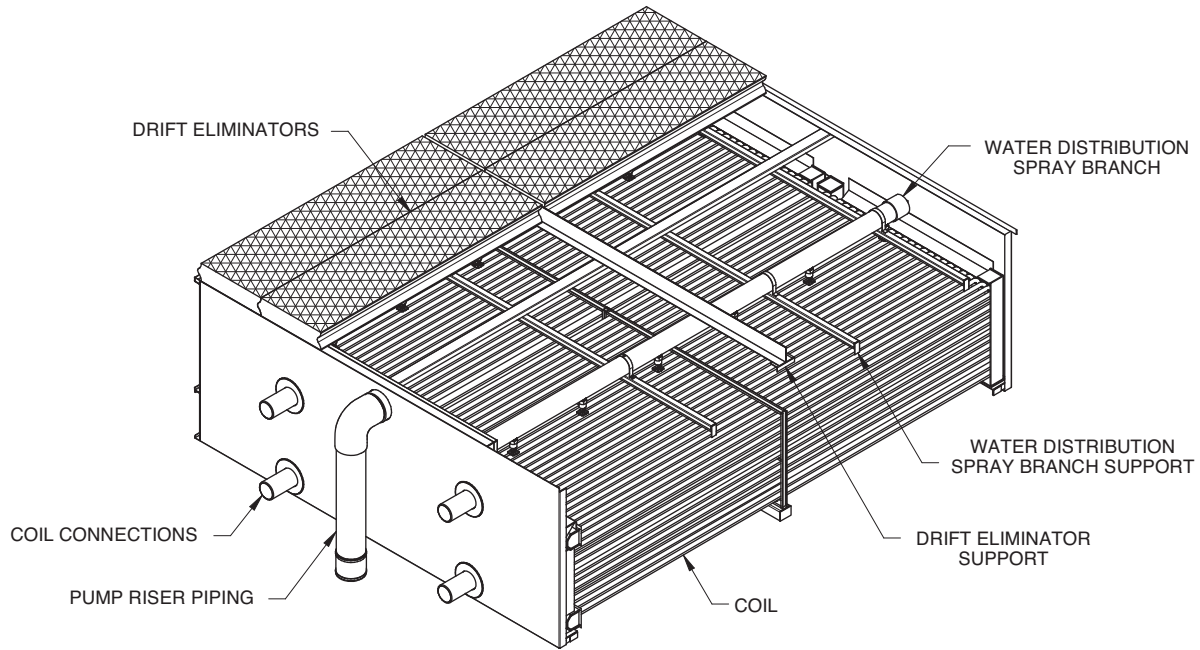

PAN SECTION

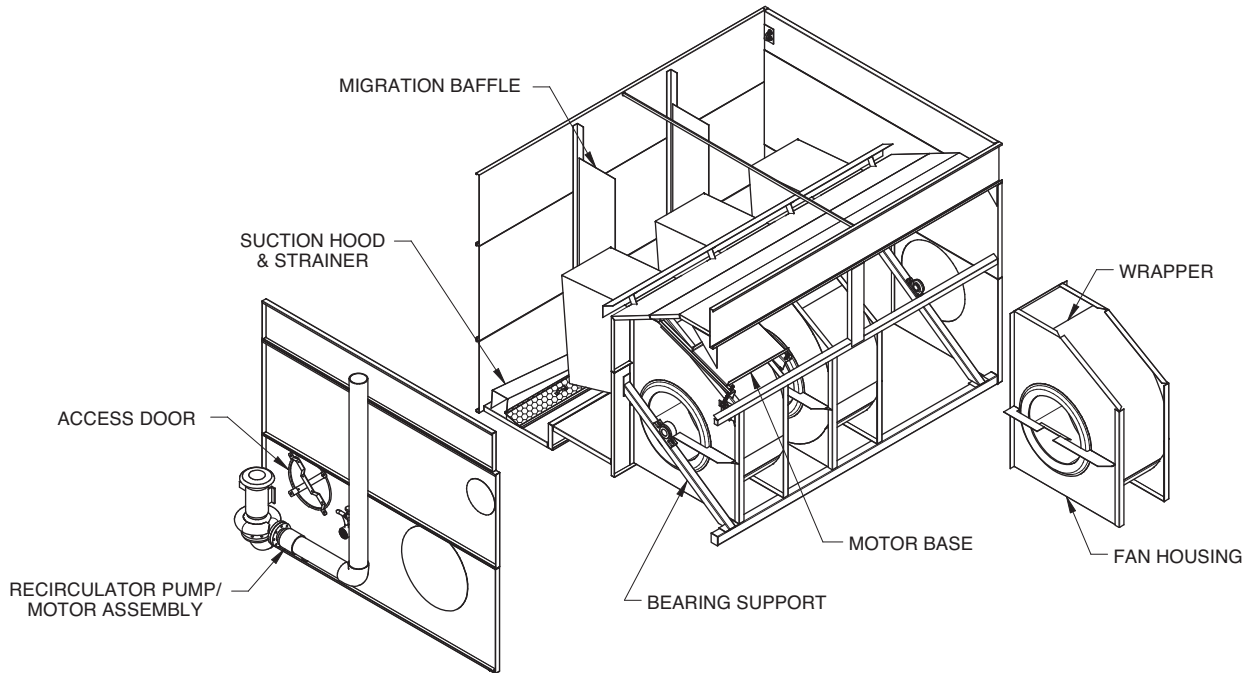

LRC/LRWB/eco-LRWB 3' Wide Units

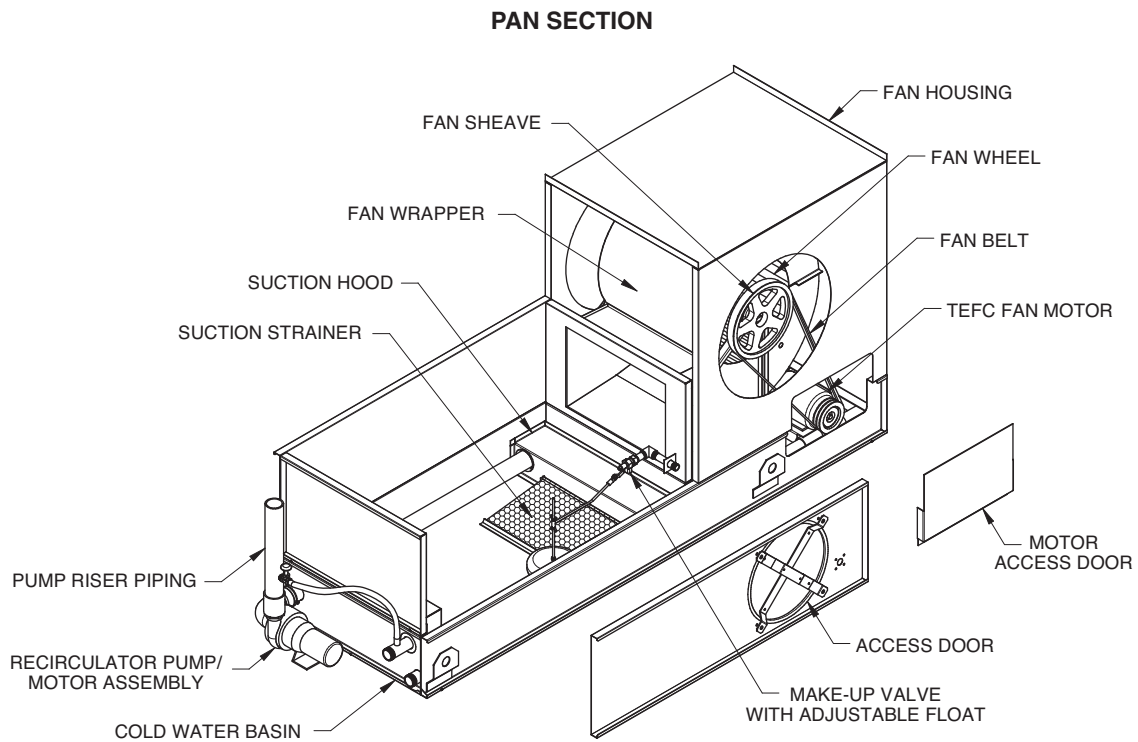
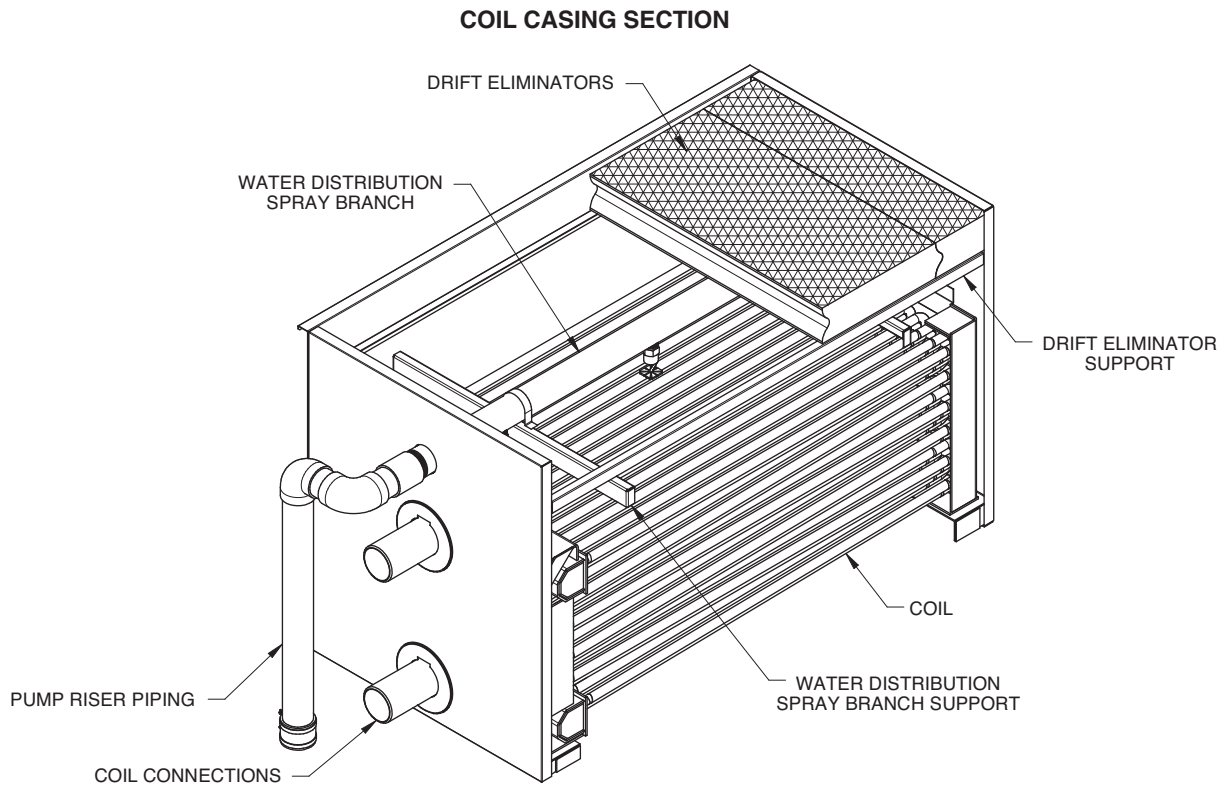

LRC/LRWB/eco-LRWB 5' Wide Units

COIL CASING SECTION

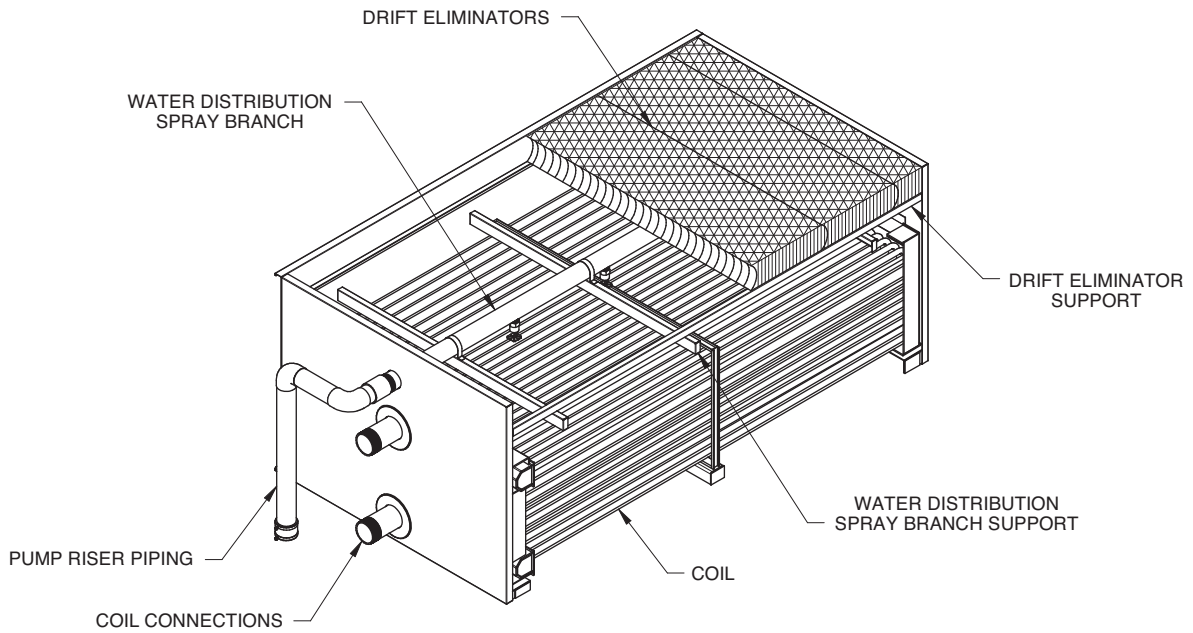

PAN SECTION

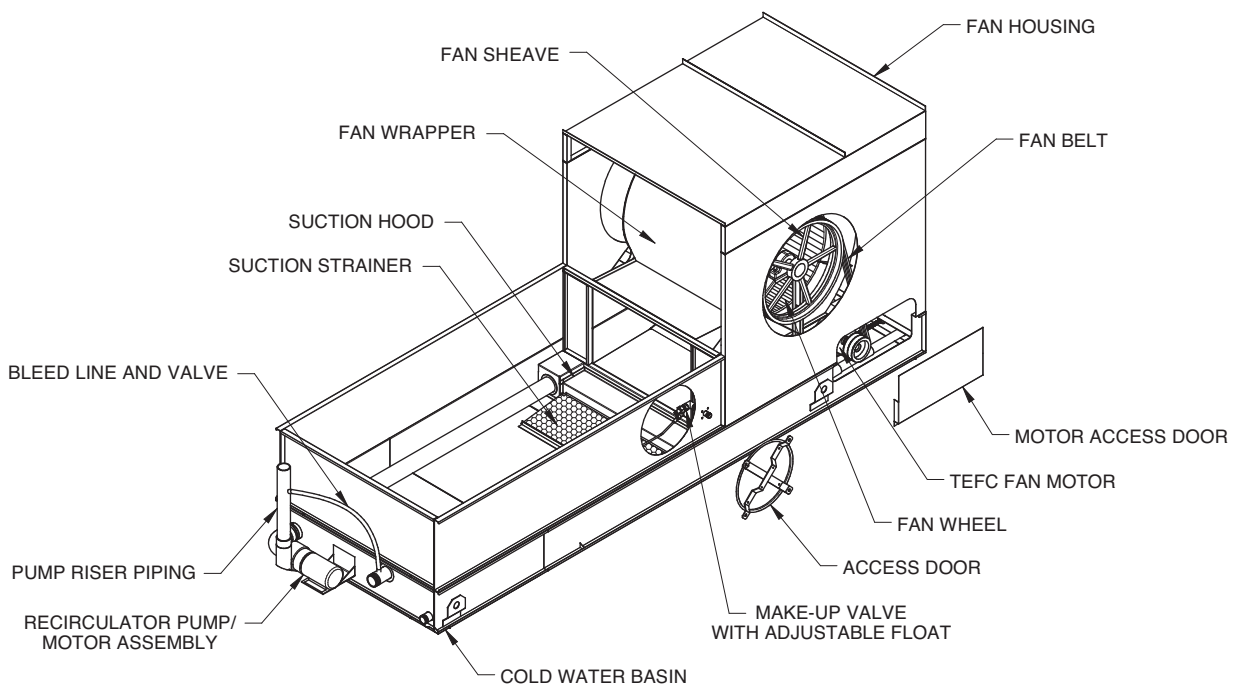

LRC/LRWB/eco-LRWB 8' Wide Units

COIL CASING SECTION

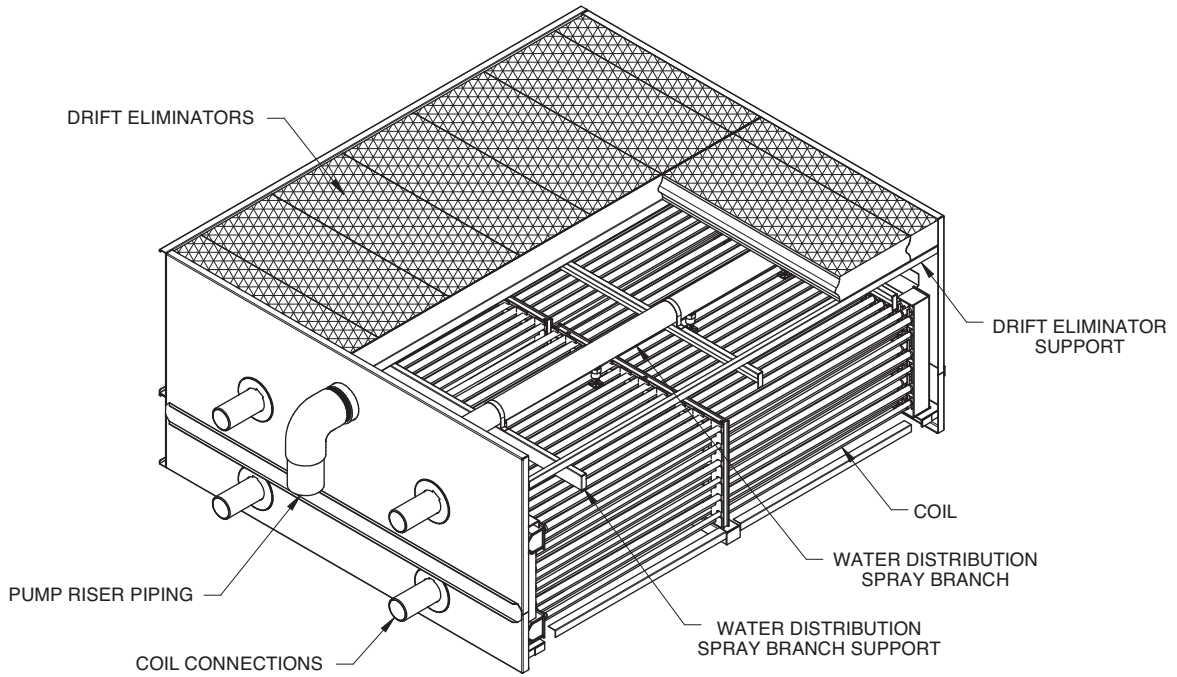

PAN SECTION

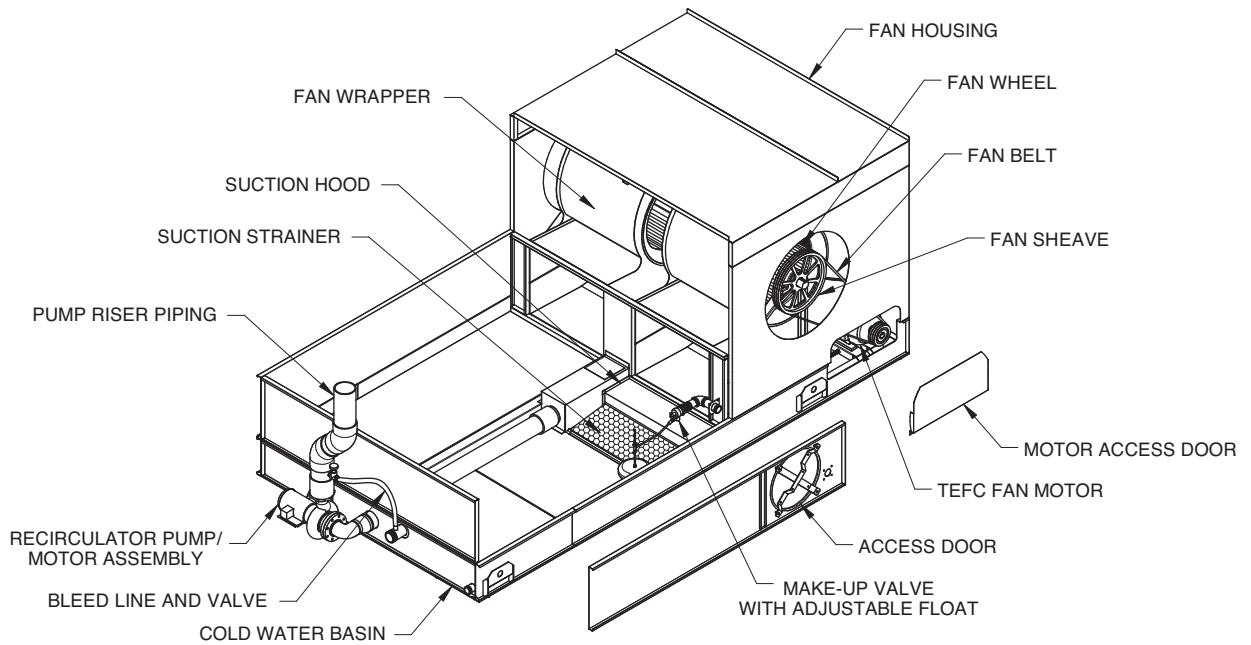

PMC-E 5' Wide Units

COIL CASING SECTION

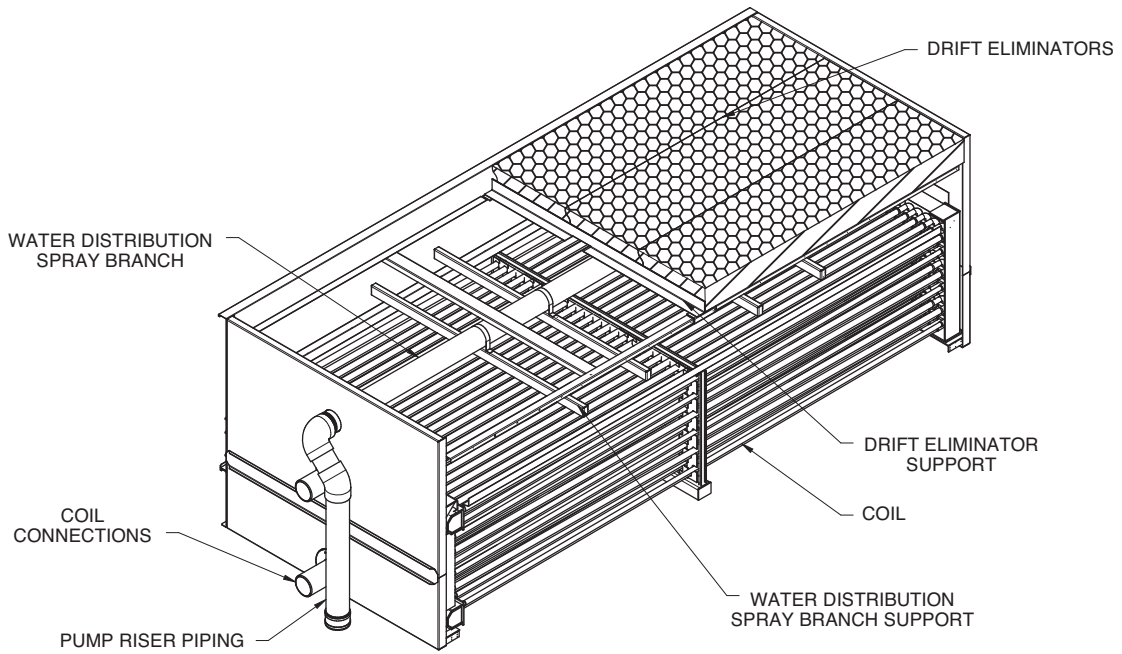

PAN SECTION

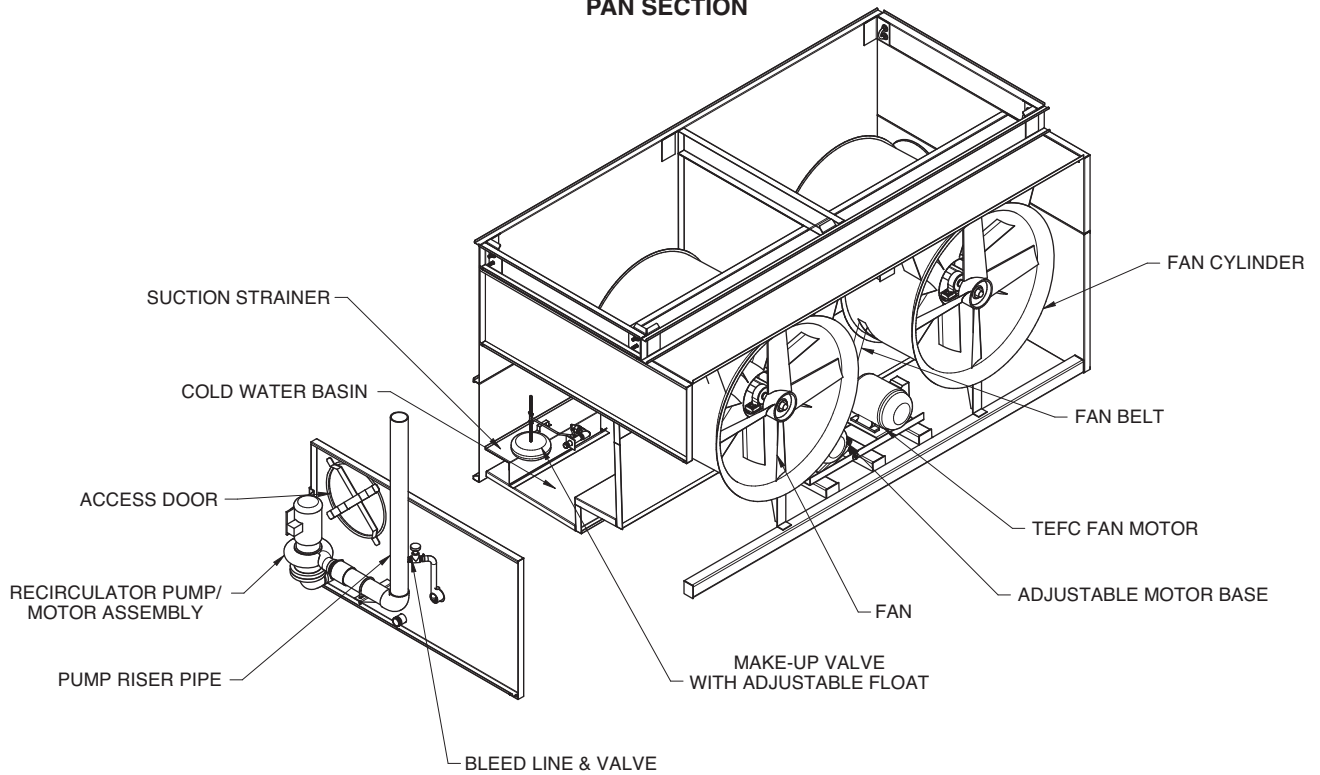

PMC-E/PMWQ 10' and 12' Wide Units

COIL CASING SECTION

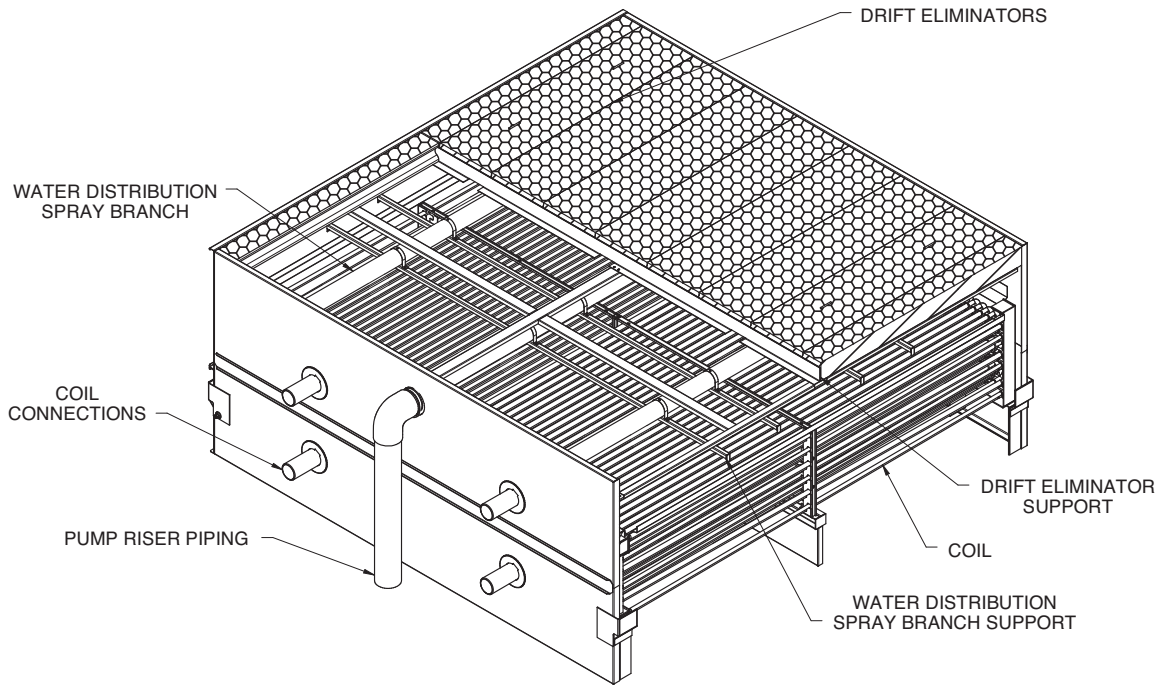

PAN SECTION

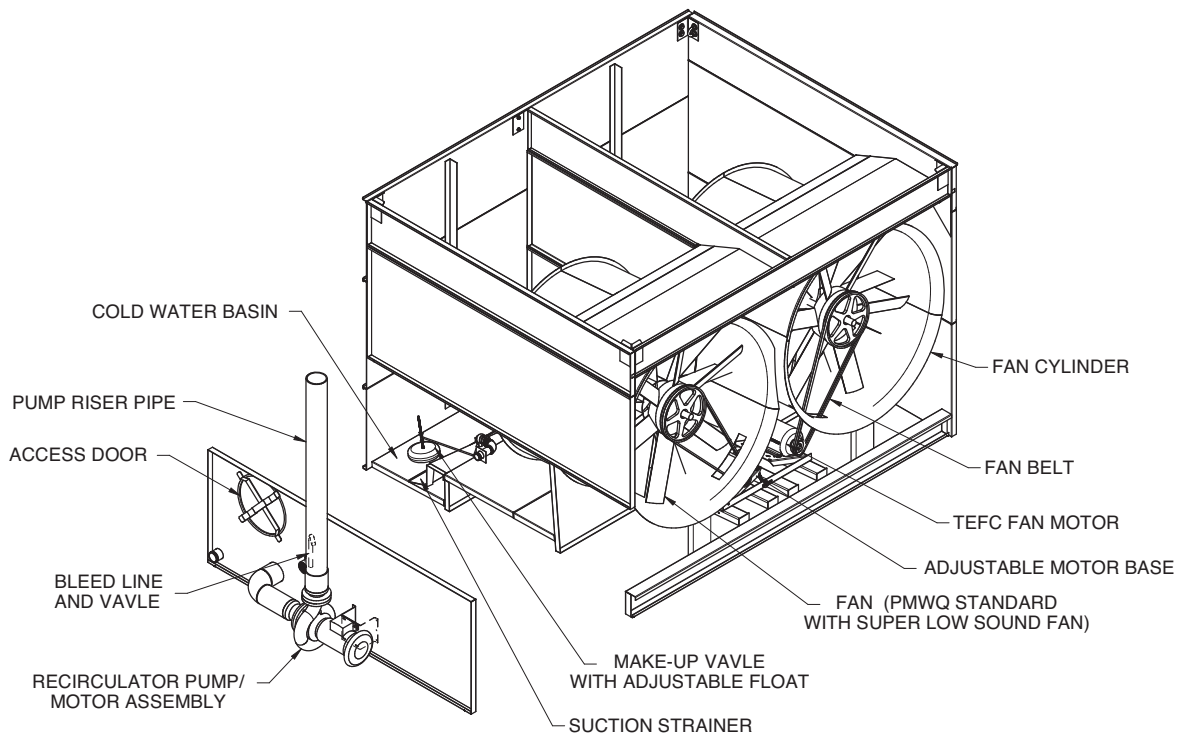



Notes:



Operation and Maintenance Instructions

Notes:



Notes:



EVAPCO, Inc. • P.O. Box 1300 • Westminster, MD 21158 USA
PHONE: 410-756-2600 • FAX: 410-756-6450 • E-MAIL: marketing@evapco.com

©2014 EVAPCO, Inc.



Printed on recycled paper
using soy-based ink