



Rigging and Assembly Instructions

17' WIDE AT/UT/USS INDUCED DRAFT COOLING TOWERS

EVAPCO Products are Manufactured Worldwide

EVAPCO, Inc. — World Headquarters & Research/Development Center

EVAPCO, Inc. • P.O. Box 1300 • Westminster, MD 21158 USA
PHONE: 410-756-2600 • FAX: 410-756-6450 • E-MAIL: marketing@evapco.com

EVAPCO North America

EVAPCO, Inc.

World Headquarters
P.O. Box 1300
Westminster, MD 21158 USA
Phone: 410-756-2600
Fax: 410-756-6450
E-mail: marketing@evapco.com

EVAPCO East

5151 Allendale Lane
Taneytown, MD 21787 USA
Phone: 410-756-2600
Fax: 410-756-6450
E-mail: marketing@evapco.com

EVAPCO Midwest

1723 York Road
Greenup, IL 62428 USA
Phone: 217-923-3431
Fax: 217-923-3300
E-mail: evapcomw@evapcomw.com

EVAPCO West

1900 West Almond Avenue
Madera, CA 93637 USA
Phone: 559-673-2207
Fax: 559-673-2378
E-mail: contact@evapcowest.com

EVAPCO Iowa

925 Quality Drive
Lake View, IA 51450 USA
Phone: 712-657-3223
Fax: 712-657-3226

EVAPCO Iowa

Sales & Engineering
215 1st Street, NE
P.O. Box 88
Medford, MN 55049 USA
Phone: 507-446-8005
Fax: 507-446-8239
E-mail: evapcomn@evapcomn.com

EVAPCO Northwest

5775 S.W. Jean Road, Suite 104
Lake Oswego, Oregon 97035 USA
Phone: 503-639-2137
Fax: 503-639-1800

EVAPCO Newton

701 East Jourdan Street
Newton, IL 62448 USA
Phone: 618-783-3433
Fax: 618-783-3499
E-mail: evapcomw@evapcomw.com

EVAPCO-BLCT Dry Cooling, Inc.

981 US Highway 22 West
Bridgewater, New Jersey 08807 USA
Phone: 1-908-379-2665
E-mail: info@evapco-blct.com

Refrigeration Valves & Systems Corporation

A wholly owned subsidiary of EVAPCO, Inc.
1520 Crosswind Dr.
Bryan, TX 77808 USA
Phone: 979-778-0095
Fax: 979-778-0030
E-mail: rvs@rvscorp.com

EvapTech, Inc.

A wholly owned subsidiary of EVAPCO, Inc.
8331 Nieman Road
Lenexa, KS 66214 USA
Phone: 913-322-5165
Fax: 913-322-5166
E-mail: marketing@evaptech.com

Tower Components, Inc.

A wholly owned subsidiary of EVAPCO, Inc.
5960 US HWY 64E
Ramseur, NC 27316
Phone: 336-824-2102
Fax: 336-824-2190
E-mail: mail@towercomponentsinc.com

EVAPCO Europe

EVAPCO Europe BVBA

European Headquarters
Industrieterrein Oost 4010
3700 Tongeren, Belgium
Phone: (32) 12-395029
Fax: (32) 12-238527
E-mail: evapco.europe@evapco.be

EVAPCO Europe, S.r.l.

Via Giro Menotti 10
I-20017 Passirana di Rho
Milan, Italy
Phone: (39) 02-939-9041
Fax: (39) 02-935-00840
E-mail: evapcoeuropa@evapco.it

EVAPCO Europe, S.r.l.

Via Dosso 2
23020 Piateda Sondrio, Italy

EVAPCO Europe GmbH

Meerbuscher Straße 64-78
Haus 5
40670 Meerbusch, Germany
Phone: (49) 2159-69560
Fax: (49) 2159-695611
E-mail: info@evapco.de

Flex coil a/s

A wholly owned subsidiary of EVAPCO, Inc.
Knøsgårdvej 115
DK-9440 Aabybro Denmark
Phone: (45) 9824 4999
Fax: (45) 9824 4990
E-mail: info@flexcoil.dk

EVAPCO S.A. (Pty.) Ltd.

A licensed manufacturer of EVAPCO, Inc.
18 Quality Road
Isando 1600
Republic of South Africa
Phone: (27) 11-392-6630
Fax: (27) 11-392-6615
E-mail: evapco@evapco.co.za

Evap Egypt Engineering Industries Co.

A licensed manufacturer of EVAPCO, Inc.
5 El Nasr Road
Nasr City, Cairo, Egypt
Phone: 2 02 24022866/2 02 24044997
Fax: 2 02 24044667/2 02 24044668
E-mail: Primacool@link.net / Shady@primacool.net

EVAPCO Asia/Pacific

EVAPCO Asia/Pacific Headquarters

1159 Luoning Rd. Baoshan Industrial Zone
Shanghai, P. R. China, Postal Code: 200949
Phone: (86) 21-6687-7786
Fax: (86) 21-6687-7008
E-mail: marketing@evapcochina.com

EVAPCO (Shanghai) Refrigeration Equipment Co., Ltd.

1159 Louning Rd., Baoshan Industrial Zone
Shanghai, P.R. China, Postal Code: 200949
Phone: (86) 21-6687-7786
Fax: (86) 21-6687-7008
E-mail: marketing@evapcochina.com

Beijing EVAPCO Refrigeration Equipment Co., Ltd.

Yan Qi Industrial Development District
Huai Rou County
Beijing, P.R. China, Postal Code: 101407
Phone: (86) 10 6166-7238
Fax: (86) 10 6166-7395
E-mail: evapcoobj@evapcochina.com

EVAPCO Australia (Pty.) Ltd.

34-42 Melbourne Road
P.O. Box 436
Riverstone, N.S.W. Australia 2765
Phone: (61) 2 9627-3322
Fax: (61) 2 9627-1715
E-mail: sales@evapco.com.au

EVAPCO Composites Sdn. Bhd

No. 70 (Lot 1289) Jalan Industri 2/3
Rawang Integrated Industrial Park
Rawang, Selangor, 48000 Malaysia
Phone: 60 3 6092-2209
Fax: 60 3 6092-2210

EvapTech Asia Pacific Sdn. Bhd

A wholly owned subsidiary of EvapTech, Inc.
B-6-1, IOI Boulevard
Jalan Kenari 5, Bandar Puchong Jaya
47170 Puchong, Selangor Darul Ehsan
Malaysia
Phone: (60-3) 8070-7255
Fax: (60-3) 8070-5731
E-mail: marketing-ap@evaptech.com

Visit EVAPCO's Website at: <http://www.evapco.com>

EVAPCO...SPECIALISTS IN HEAT TRANSFER PRODUCTS AND SERVICES.



Introduction

Thank you for purchasing your EVAPCO cooling tower. This manual will provide instructions for installation of the cooling tower. If you have purchased a model UT cooling tower (Super Low Sound Fan option), please be sure to pay attention to the proper rigging instructions for that special option enclosed herein. If any questions arise during the installation, please contact your local EVAPCO representative or us directly at our Global Headquarters location.

International Building Code Provisions

The International Building Code (IBC) is a comprehensive set of regulations addressing the structural design and installation requirements for building systems – including HVAC and industrial refrigeration equipment. As of June 2008, all 50 states plus Washington D.C. have adopted the International Building Code. The code provisions require that evaporative cooling equipment and all other components permanently installed on a structure must meet the same seismic design criteria as the building. The AT/UT/USS Series of Open Cooling Towers are IBC 2009 compliant up to 1g with standard construction and up to 5.12g with additional structural modifications.

All items attached to the Evapco AT/UT/USS cooling tower must be independently reviewed and isolated to meet applicable wind and seismic loads. This includes piping, ductwork, conduit, and electrical connections. These items must be flexibly attached to the Evapco unit so as not to transmit additional loads to the equipment as a result of seismic or wind forces.

Method of Shipment

All models are shipped with the top section(s) separate from the bottom section(s). These sections have mating flanges and will join together in a watertight joint when sealed and bolted together as described in the following instructions. Miscellaneous items, such as sealer, self-tapping screws and any other required materials, are packaged in a rigging box which is placed inside the basin for shipment. On all cooling towers covered by this bulletin, drip channels and splash guards ship loose in the basin for field installation. On 17' wide units, the motors and belts are shipped inside the pan for mounting during installation.

Storage

Do not place tarps or other coverings over the top of the units if they are to be stored before installation. Excessive heat can build up if the units are covered, causing possible damage to the PVC eliminators, PVC louvers, or PVC fill. **For extended storage beyond six months, rotate the fan and fan motor shaft(s) monthly. Also, the fan motor and fan shaft bearings should be purged and regreased prior to start-up.**

Structural Steel Support

Three structural “I” beams running the length of the unit. Two beams should be located underneath the outer flanges of the unit and one longitudinally along the center of the unit. See Figure 1.

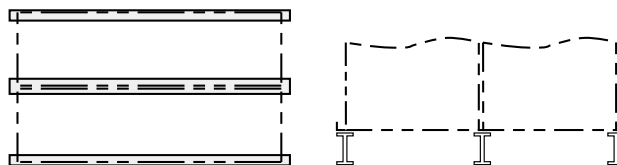

Figure 1 – Structural Steel Support

Lifting Bottom Section

Lifting Devices are located in the upper corners of the bottom section for lifting and final positioning purposes as shown in Figure 2. The hook of the crane must be a minimum dimension of "H" above the top of the section being lifted to prevent undue strain on the lifting devices. See Table 1 for the minimum "H" dimension. These lifting devices should not be used for extended lifts or where any hazard exists unless safety slings are employed under the section. (See "Extended Lifts" on page 6 for proper arrangement). Bolt the bottom section to the steel support before rigging the top section.

Table 1 – Minimum "H" Dimension for Bottom Sections

Model No.	Min. "H" Dim.
217-59 to 99	10 Feet
217-111 to 911	11 Feet
217-412 to 912	12 Feet
217-214 to 914	15 Feet

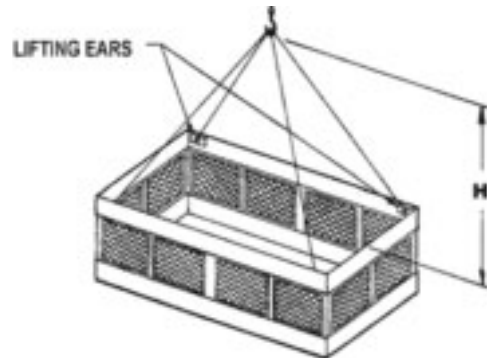

Figure 2 – Bottom Section

Joining Multi-Cell Units Bottom Sections

On all models, the two bottom sections are shipped separately and are furnished with a connecting equalizer flume between them. In addition to the equalizer flumes, these units are provided with drip channels and splash guards to keep water from exiting between the cells. All 17' wide units have one horizontal drip channel and two vertical splash guards (one for each side). On all cooling towers, the equalizer flume is to be located on the sides of adjoining bottom sections. This flume box is shipped loose and must be installed to both bottom sections. It is important to connect the equalizer flume to balance the water level in the pans for the proper pump suction operation. The following procedures are to be performed in sequence.

1. Install one bottom section of the unit on structural steel and secure as described on page 3.
2. Mating flanges which will make contact with others should be cleaned to remove dirt, grease and moisture. Apply a layer of sealer tape on one side panel centered over the flume box holes as shown in Figure 3. Remove paper backing strip from the sealer tape.
3. On all models, the side of the flume box which has studs installed in it should now be connected to the side panel. The studs are pushed through the sealer tape and holes of the side panel and are secured by washers, lock washers and nuts.
4. Clean the mating flanges on the other side of the equalizer flume on the end to be field connected. Apply a layer of sealer tape on the flange, centered between the hole centers and the outside edge. Remove paper backing strip from the sealer tape.
5. Clean the mating surface of the side panel of any dirt, grease or moisture. Rig the second bottom section adjacent to the equalizer. See Figure 4.
6. Align the bolt holes in the equalizer flume and equalizer opening with drift pins (drift pins shall be provided by others) while drawing the second bottom section against the flanged connection.

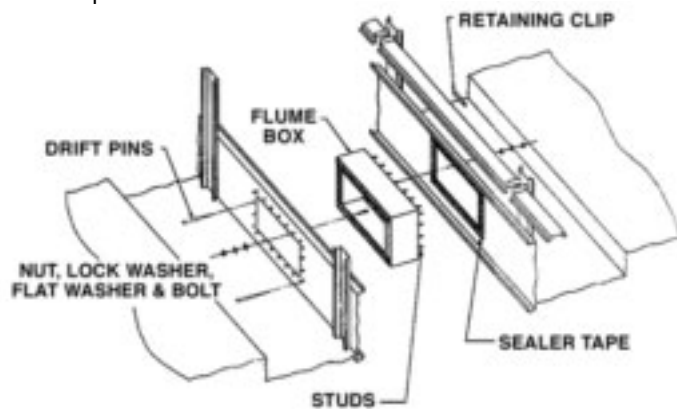

Figure 3 – Flume Assembly

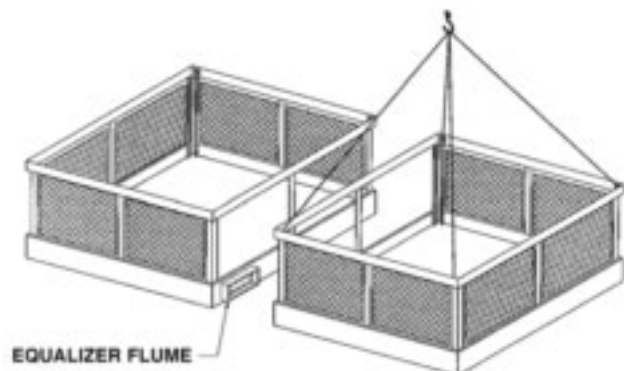

Figure 4 – Equalizer Flume Rigging Detail

7. Install 3/8" bolts, nuts and washers in every hole around the equalizer opening and tighten.
8. Bolt the second bottom section to the steel support.
9. Remove the 1/4" bolts which hold the drip channel retaining clips to the side panel. Place the drip channel over the adjoining pan section flanges. Turn around the retaining clips and re-install them using the same hardware. See Figures 3 & 5.
10. Place the vertical splash guard in the bend of the vertical supports. On galvanized units, attach the vertical splash guard using 5/16" self-tapping screws. On stainless steel units, attach the vertical splash guard using 5/16" stainless steel nuts and bolts. See Figure 6. Holes must be drilled into the vertical supports in the field to attach the vertical splash guards.

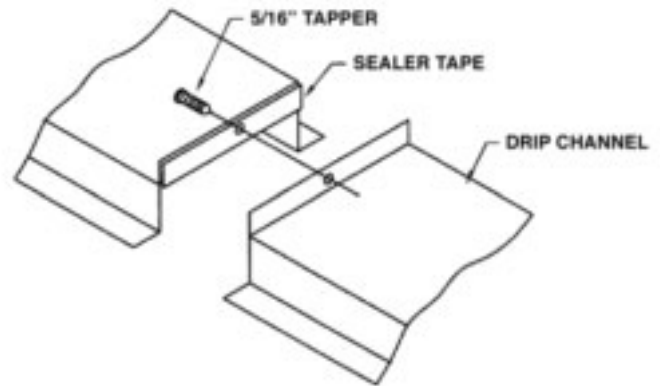

Figure 5 – Attachment of Drip Channel

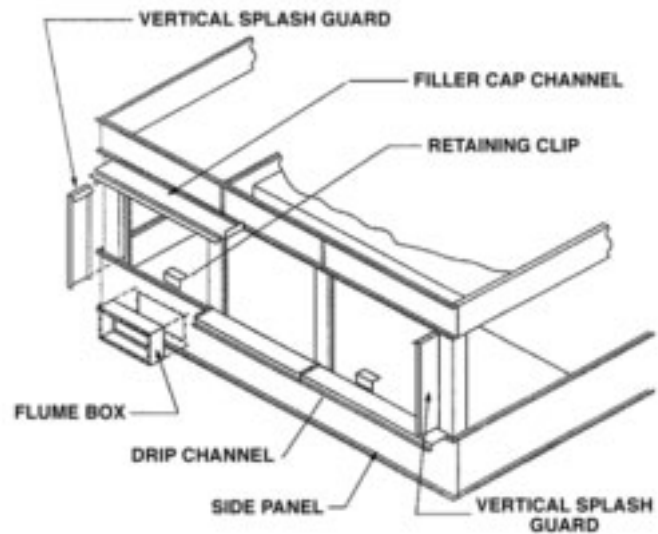

Figure 6 – Attachment of Drip Channel and Splash Guards

Optional Equalizer Blank-Off Plate For All Multi-Cell Units

An accessory is available to isolate the bottom sections for individual cell operation, periodic cleaning or maintenance. This optional equalizer blank-off plate is factory installed on the equalizer flume inside of the pan and secured by wing nuts. See Figure 7.

For units not requiring the blank-off plate under normal operating conditions, remove the wing nuts, washers, plate mand gasket. Reinstall washers and wing nuts for proper leakfree operation of the flume.

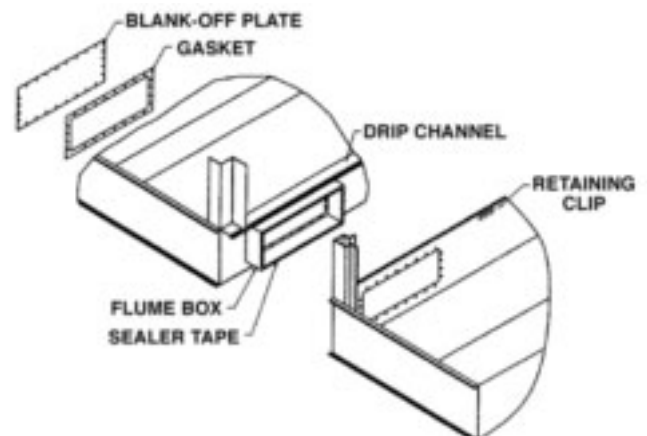

Figure 7 – Optional Blank-Off Plate on the Equalizer Flume

Application of Sealer Tape

Once the bottom section has been set on the supporting steel and bolted in place, the top flanges should be wiped down to remove any dirt or moisture. Sealer tape should be placed over the mounting hole centerline on the side flanges. **Apply two strips of sealer tape, one partially overlapping the other, on the end flanges (8.5' end).** The sealer tape should overlap on the corners as shown in Figure 8. Do not splice the sealer tape along the end flanges and preferably not on the side flanges if it can be avoided. **Always remove the paper backing from the sealer tape.**

Sealer tape must be applied to all internal flanges. See Figure 9.

Note: On all 17' wide units, motors should be mounted prior to lifting the topsection as shown in the "External Motor Installation" section, page 7.

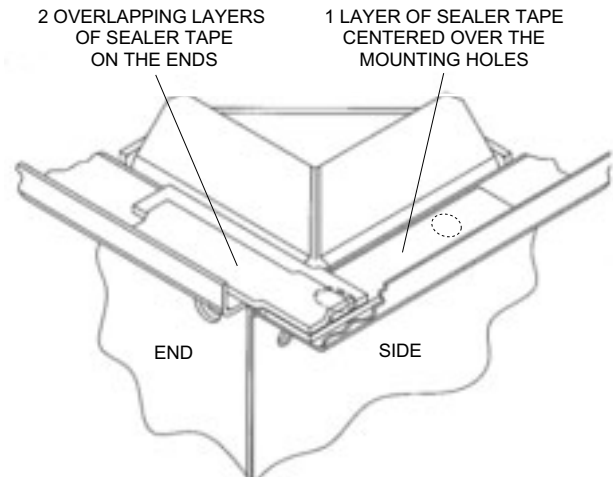

Figure 8 – Sealer Tape on Flange of Bottom Section

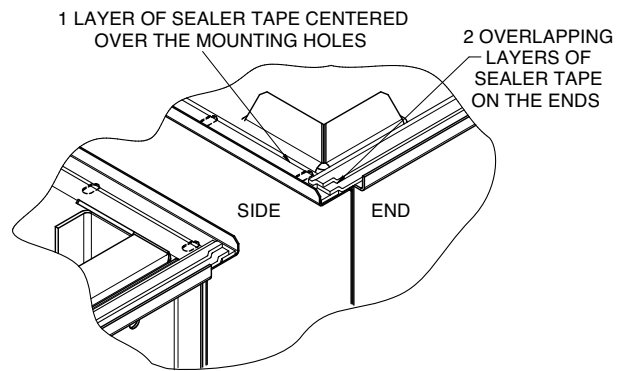

Figure 9 – Sealer Tape Detail for Center Joint

Rigging Top Section

“U” bolts are provided in the four corners of the top section for lifting and final positioning. See Figure 10. The hook of the crane must be a minimum dimension “H” above the top section being lifted to prevent undue strain on the “U” bolts. See Table 2 for the minimum “H” dimension.

Table 2 – Minimum “H” Dimension for Top Sections

Model No.	Standard Fan	Super Low Sound Fan
217-59 to 99	9 Feet	12 Feet
217-111 to 911	10 Feet	14 Feet
217-412 to 912	10 Feet	12 Feet
217-214 to 914	12 Feet	12 Feet

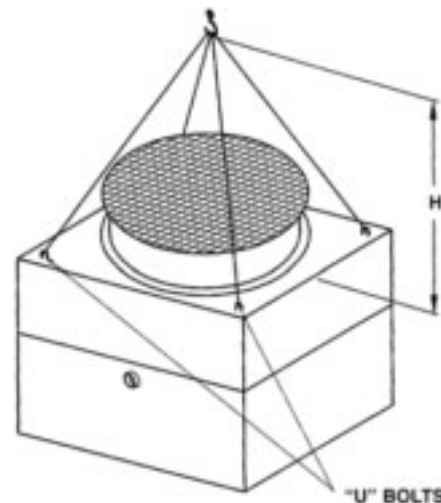

Figure 10 – AT/UT/USS Top Section(s)

Extended Lifts

Important: The lifting devices and “U” bolts should be used for final positioning only and for lifting where no danger exists. If they are used for extended lifts, safety slings should be provided under the sections.

Safety slings and skids should be removed before final positioning of the unit.

The preferred method for extended lifts is to use slings under the unit. See Figures 11a & 11b. Spreader should always be used between the cables at the top of the section to prevent damage to the upper flanges or fan cylinders.

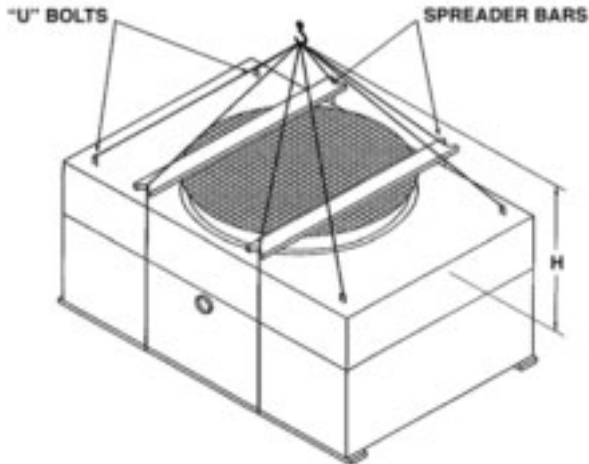

AT/UT/USS Top Section

Figure 11a – Proper Rigging Method for Extended Lifts (top section)

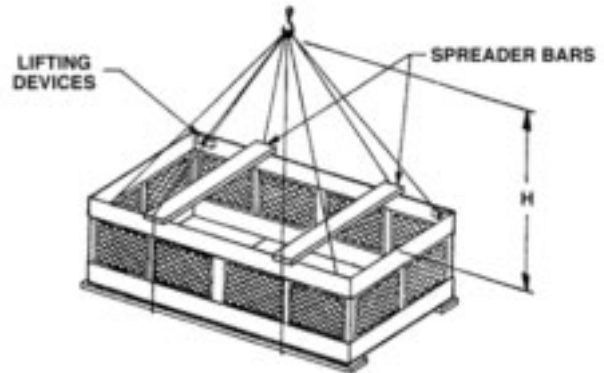

AT/UT/USS Bottom Section

Figure 11a – Proper Rigging Method for Extended Lifts (bottom section)

Assembly of the Top Section to the Bottom Section

Before assembling the top section to the bottom section, remove any loose parts shipped in the pan. The fan motors and protective covers are shipped loose to avoid damage.

Wipe the flanges on the bottom of the top section. Check to see that the water distribution connection on the top section is in the correct position relative to the bottom section (see certified print). Units are also provided with match markings on each section (e.g. A1 of bottom section should match up with A1 of top section).

Lower the top section to within several inches of the bottom section making sure the two sections do not touch and the sealer is not disturbed. Fasten all four corners. Install the remaining fasteners, working from the corners toward the center. Fasteners must be installed in every hole on the side flange. None are required on the end flanges. Galvanized and stainless steel units will use 3/8” nuts and bolts. See Figure 12.

All units will have multiple top sections that will be mounted in the same fashion as described above for the first section. When assembling the top sections to the bottom sections, nuts and bolts are required along all mating flanges. All nuts and bolts are driven upward through the mating flange. See Figure 12. **Nuts and bolts are driven downward through the mating flange from the ends. The nuts and bolts that cannot be reached from the ends must be driven downward from the top of the unit with an extension tool.**

Note: 3/8” stainless steel nuts and bolts are used on stainless steel models.

Caution: 17’ wide units cannot be rigged fully assembled.

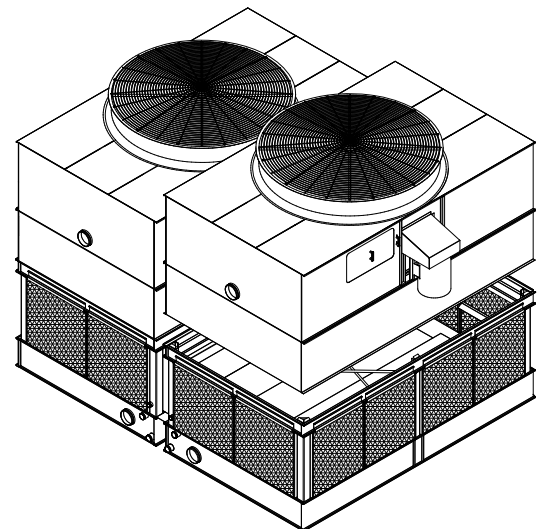

Figure 12 – Mating Upper Section to Bottom Section

After the top sections have been secured to the bottom sections, a Filler Cap Channel should be installed between the top sections to prevent debris from entering the bottom sections. These sections are simply positioned over the mating flanges as shown in figure 13. The Filler Cap Channel can be installed from inside the unit by inserting the channel through the space between the basin and casing sections. The channel does not require fastening.

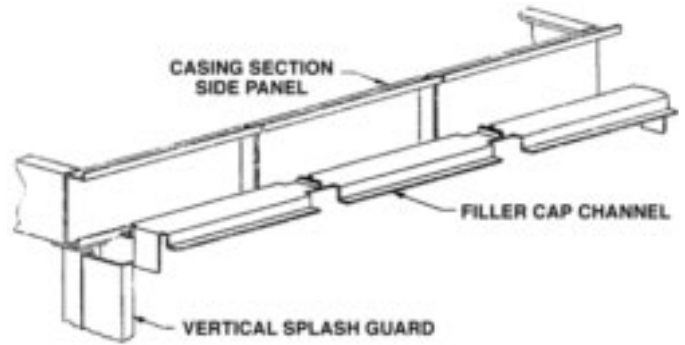

Figure 13 – Filler Cap Channel Assembly

External Motor Installation

1. Study Figure 14 before installing the motor base on the unit.
2. Insert the lifting device into "U" bolt **A** on motor base **B**.
3. Lift the motor base and insert the pivot pin **C** down into hole **E** and pivot pin **F** into hole **D**.
4. Install washer and nut (do not over tighten) on pivot pins. Install jam nut on pivot pin **C**.
5. Insert "J" bolts **G** into holes **H**. Install flat washers and cotter pins. Place nuts and washers on threaded portion of "J" bolts. These will be behind the motor base installed in the next step.
6. Insert "J" bolts into holes **J** in the motor base. Install flat washers, lock washer and nuts. Remove lifting device from the "U" bolt on the motor base. Position motor base toward top section of unit for belt installation.
7. Install Powerband belt **K** (Figure 15) around fan sheave and motor sheave. Tighten belt by adjusting nuts on "J" bolts. Do not over tighten the belts. The center of the belt should deflect approximately 3/4" with moderate hand pressure.
8. Measure to see that the top and bottom of the motor base are the same distance out from the casing of the unit. This should insure that the sheaves are properly aligned since they have been pre-set at the factory. As a final check, lay a straight edge from sheave to sheave. There should be four point contact. See Figure 16. Adjust the position of the motor sheave as necessary.
9. To install Motor Guard **L**, match up hinges and install hinge pins **M**. See Figure 15.
10. Close Motor Guard and install (2) wing bolts **N**.

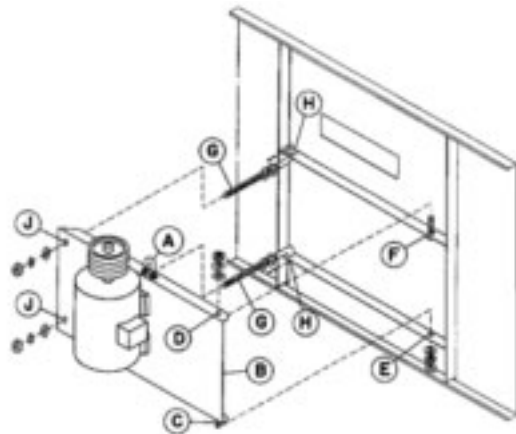

Figure 14 – External Motor Installation

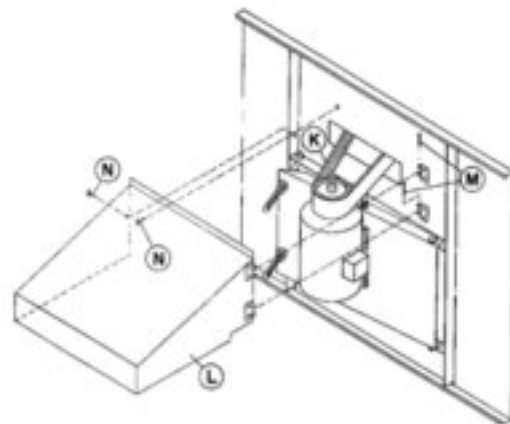

Figure 15 – Motor Guard and Powerband Belt Installation

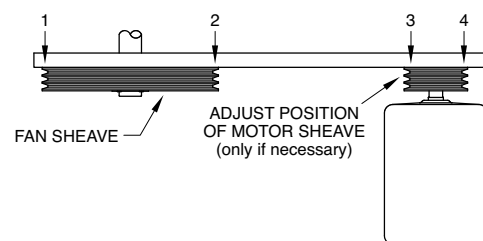

Figure 16 – Sheave Alignment Check

Optional Motor & Gear Box Davit

An accessory is available to aid the removal of fan motors and gear boxes. The assembly consists of a davit and a mounting base that is to be attached to the side of the unit next to the access door (See Figure 17). Both of these items will ship in the unit's basin. On multiple cell units, there will be a mounting base on each cell. Use the following procedure to install the mounting base.

1. Align the mounting channel with 3/8" bolts and flat washers to the mounting bracket (factory mounted).
2. Use 3/8" flat washers, lock washer and nuts to secure the mounting channel to the bracket (See Figure 18).

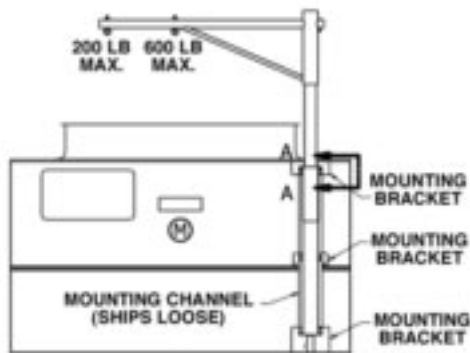

Figure 17 – Dual Point Davit Arrangement

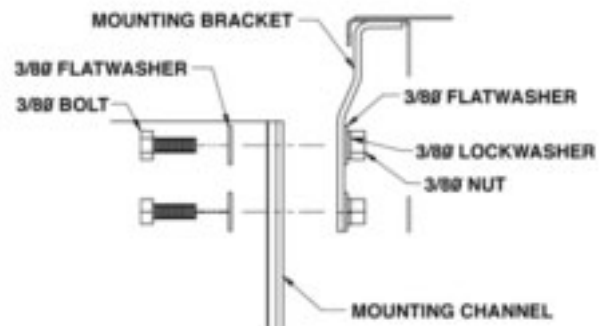

Figure 18 – Mounting Base Installation

Accessing Internal Mating Flanges on Units with Wind Panels or Water Tight Partitions

When wind panels or water tight partitions are supplied between bottom sections, the upper half of the partition must be lowered to gain access to the upper mating angles. The upper partition can be lowered by removing the bolts along the bottom edge of the panel. Bolt access is from the inside of the unit. After the mounting angle bolts or screws are installed, raise the upper partition and bolt it back into its original position. Seal the edges and bolt heads of the wind panel with the supplied caulk sealer. See Figure 19.

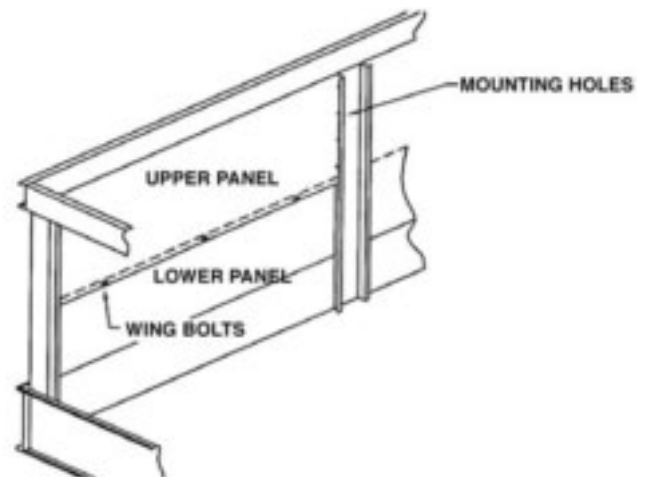

Figure 19 – Lowering of Wind Panels

Assembly of Sloped Ladders

When sloped ladders are supplied with a unit, they are shipped in the basin of the unit. One sloped ladder will be provided for each cell. Assembly is identical for each cell.

Sloped ladders are attached at a minimum of three points. Taller units will be attached at four points. At each point of attachment, the ladder will be fitted with a ladder bracket assembly. The ladder bracket assembly looks like a metal box and is shown in detail (component #4) in Figure 20. The upper two assembly brackets will be rigidly mounted to the ladder and are not adjustable. These two brackets define the slope of the ladder. The lower brackets are adjustable.

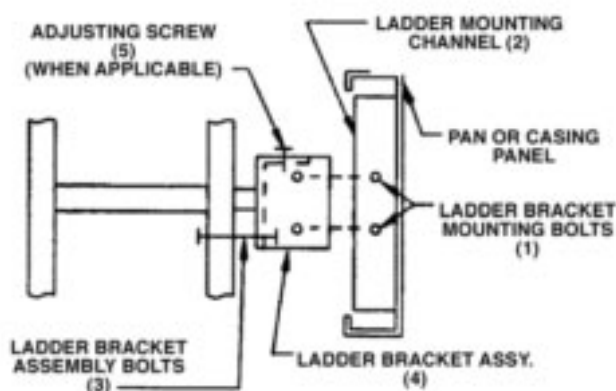

Figure 20 – Detail of Ladder, Ladder Bracket Assembly and Mounting Channel

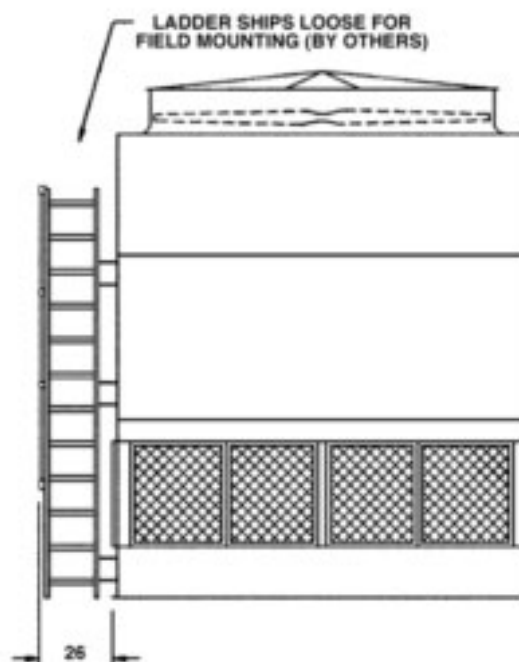

Figure 21a – End View of Ladder Assembly

To install the ladder assembly, follow the steps outlined below which refer to Figure 20:

3. Remove the ladder bracket mounting bolts (1) from the ladder mounting channels (2) on pan and casing sections.
4. Loosen, but do not remove, the ladder bracket and assembly bolts (3).
5. Slide the ladder bracket assembly (4) over the ladder mounting channels (2) located on the pan and casing sections. Do not remove the ladder bracket assembly (4) from the ladder.
6. Align the bolt holes and reinstall the ladder bracket mounting bolts (1) through the ladder bracket assembly and the ladder mounting channels (2).
7. Tighten all bolts.
8. Tighten the adjusting screw (5) in the adjustable mounting bracket where applicable.

Note: Upper Section of Unit Must Be Properly Oriented with Respect to Lower Section. All Mounting Brackets Must be on Same Side of Unit. Refer to Certified Print For Proper Orientation.

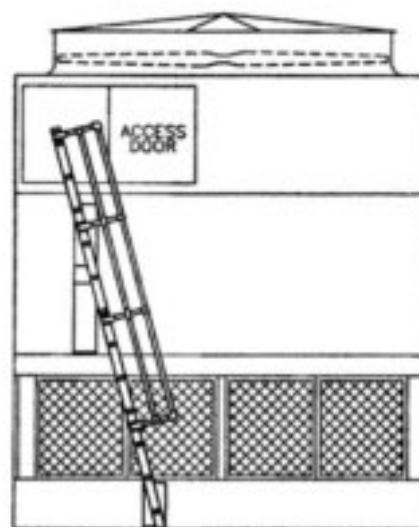

Figure 21b – Side View of Ladder Assembly



Field Assembly of Working Platform and Ladder

The working platform/ladder assemblies are shipped in the basin of the unit. In some cases they are shipped separately due to basin accessories that interfere with storage. The platform is partially assembled prior to shipment for minimal field assembly.

For 17' wide units, there will be one working platform ladder assembly per fan section.

The platform and ladder assembly should be attached after the unit is fully rigged following the instructions below.
AT/USS Cooling Towers

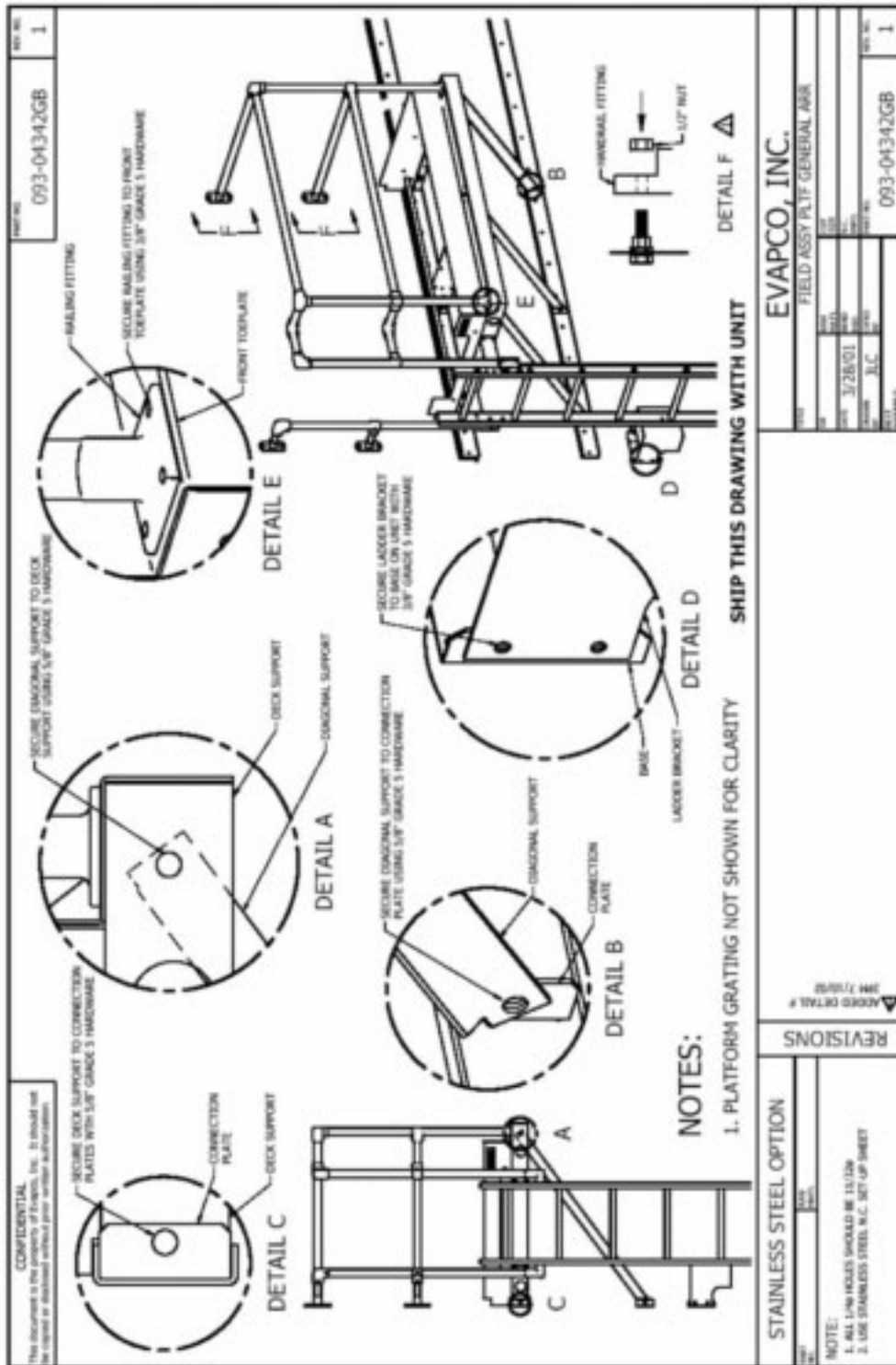

General Information - Start-up & Maintenance Start-up Details

Shipping Chocks and Debris

Remove any chocks that have been placed inside the unit for shipping purposes. Clean all debris from the pan prior to start-up. Close and secure all access doors.

Bleed-off Line

Make sure a bleed line and valve are installed on the pump discharge side of the system piping to a convenient drain. The bleed-off valve should be open. For installation details, see the "Maintenance Instructions Bulletin."

Strainer

Check the strainer(s) in the pan to make sure they are in the proper location over the pump suction and alongside the anti-cavitation hood. See Figure 22.

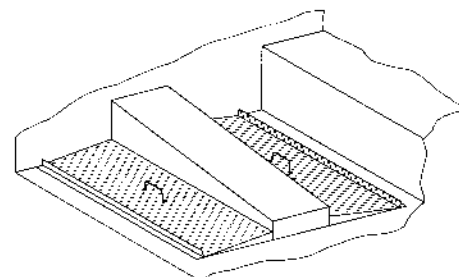

Figure 22 – Strainer Location

Screens

Protective fan screens are provided across the top of the fan cylinders of all models. Check and tighten all bolts.

Adjustment of Float Valve

The float valve should be adjusted to maintain the proper water level as specified in the maintenance instructions. At start-up, the pan should be filled to the overflow level. During operation, the water level will drop to no more than 5" below the overflow. The water level can be checked during operation by opening the removable louver section near the makeup valve while the pump is running and the fans are off.

Starting Sequence

Before starting the unit, check that all access openings, safety screens and covers are in place. Then start the unit as outlined below:

1. Fill the pan to the overflow level.
2. Start the water pumps. Check the water flow to the unit by checking the spray water pressure at the water inlet. It should be the same as the pressure indicated on the certified drawing.
3. Start the fans. Check the fans for proper rotation.

NOTE: Do not operate the fans while the pump is off. Damage to the PVC fill can result during dry operation. Always start the water pumps first, with the fan motors following.

Maintenance

Once the installation is complete and the unit is turned on, it is important that it be properly maintained. Maintenance is not difficult or time-consuming but must be done regularly to assure full performance of the unit. Refer to the maintenance instructions supplied with the unit for proper maintenance procedures.

Freeze Protection

Proper freeze protection must be provided if the unit is located in a cold climate. Refer to maintenance instructions as well as product bulletins for further information.



EVAPCO, Inc. • P.O. Box 1300 • Westminster, MD 21158 USA
PHONE: 410-756-2600 • FAX: 410-756-6450 • E-MAIL: marketing@evapco.com



Printed on recycled paper
using soy-based ink

©2013 EVAPCO, Inc.

1M/0413/YGS



RECYCLED
Paper made from
recycled material
FSC® C115175

