



CPA MAINTENANCE INSTRUCTIONS

NOTE – Failure to follow recommended maintenance procedures could void unit warranties.

Interior Sanitization:

The interior of the unit should be cleaned and sanitized periodically. The frequency of cleaning will be dependent upon the application and the HACCP procedures outlined for the air-handling unit. It is extremely critical that the chemicals used to clean the unit are compatible with the interior materials and components. It is recommended the supplier of cleaners and sanitizers for the plant be consulted so they can make recommendations on proper cleaning procedures and processes for the unit.

When cleaning the unit:

1. Make sure the unit is locked and tagged out per plant procedures.
2. Cleaning personnel should make sure to have proper protective clothing, as per their standard operating procedures.
3. Make sure all of the filters have been removed from the unit.
4. Protect any control devices inside the unit with waterproof covering.
5. If the unit is supplied with UVC lights, protect both the light and the fixture from the cleaning process.
6. Make sure that all of the drain connections are open.
7. Do not aggressively spray/wash the motor bearings. Aggressive washing can damage the seal and wash out the grease. This can cause premature failure of the bearing.
8. The coils can be cleaned however do not spray with high pressure system, especially at an angle toward the fins. This can bend the leading edge of the fins over. If the coil has aluminum fins do not use caustic cleaners.
9. Do not aggressively spray the gasketing on the filters. This can damage the gasketing.
10. Do not aggressively spray the caulked seams in the unit. This can damage or dislodge the sealing caulk.

Prior to putting the unit back in operation:

1. Make sure the interior of unit is as dry as possible. Operating before the unit is dry can cause water to be airborne and damage the electrical components or get the filters wet and damage them.
2. Make sure any drain caps that have been removed for cleaning, are replaced and sealed.
3. Remove all protective coverings used during the cleaning process.
4. Check all the caulked seams in the unit for integrity. Caulking is a routine maintenance item.
5. Check the gasketing on the filter frames. Replace if necessary.
6. Replace all filters and remove all protective material from interior components.

Pre-filter Service:

The prefilters in the CPA unit are a pleated synthetic media filter with a moisture resistant frame, each held in place with two holding clips.

The frequency of changing of the prefilters is determined by the cleanliness of the air passing through them and the proper operation of the unit during the cleanup cycle. Most prefilter systems are changed on a preventative maintenance schedule and not purely by the appearance of the filter. Visible dirt on the surface is not a true indication of full loading of the filter. However, it can be an initial indicator. If the CPA unit is supplied with a filter gauge, the filters should be changed at a 0.8" to 1.0" w.g. reading. Typical life of the filter should be anywhere from 30 days to 90 days, depending upon the application and operation of the unit.



Please call Evapco at 507-446-8005 for availability of pre-filters.

Use the following procedure to change the prefilters.

- 1) Stop the fan motor and lockout using the disconnect switch.
- 2) Remove each filter from their individual holding frame.
- 3) Inspect the filter frame gasketing, caulking between the frames and holding clips and replace if necessary.
- 4) Clean and sanitize the prefilter section.
- 5) Install the new prefilters. The prefilters should have the pleats in the vertical position if possible.
- 6) Start the fan motor.
- 7) It is suggested that the prefilters be checked after approximately 8 hours of operation to ensure that they have been installed properly.
- 8) Make note in the maintenance schedule for the unit.

Final Filter Service:

CPA units can be supplied with two types of final filters, MERV 14 or 15 and HEPA filters. These filters are typically located at the discharge of the unit. The following is the servicing procedures for the two types of filters.

MERV 14 and 15 Final Filters

The MERV 14 and 15 filters are a cartridge type filter each held with four spring holding clips. The filter media is glass microfiber media (with an optional synthetic media filter).

The MERV 14 and 15 filters should be changed when the reading on the final filter gauge indicates approximately 1.1" to 1.2" pressure drop across the filters. The pressure

drops should be read with the unit operating, all service doors closed and new prefilters in place.

Typically the final filters should last 6 months to 15 months, depending upon the cleanliness of the application, the frequency of prefilter changes, and if the unit cleanup cycle is operated properly. The filter gauge will ensure the final filters have reached their full life, and are not changed prematurely. Please contact EVAPCO at 507-446-8005 for availability of filters.

Use the following procedure to change the filters.

- 1) Stop the fan motor and lockout using disconnect switch.
- 2) Remove the fully loaded final filters. (NOTE: Maintenance personnel may want to use protective clothing and facemasks while changing.) Be careful not to dislodge any of the particles collected in the filter.
- 3) Inspect the final filter frame gasketing (in some applications the gasketing is on the filter and not the frame) and the retaining clips.
- 4) Check the caulking seal between the final filter frames. If any cracks are observed, caulk with a USDA/FDA approved sealant.
- 5) Install the new MERV 14 or 15 final filters. The pleats should be in the vertical position if possible.
- 6) Clean and sanitize the final filter section.
- 7) Start the fan motor.
- 8) Make note in the maintenance schedule for the unit that the final filters have been changed.
- 9) Check filter gauge for proper operation. Recalibrate if necessary.



HEPA Final Filters

The HEPA filters are a cartridge type filter each held with four holding clips. The filter media is glass microfiber material.

The HEPA filters should be changed when the reading on the final filter gauge indicates approximately 2.0" pressure drop across the filters. The pressure drops should be read with the unit operating, all service doors closed and the prefilters in their clean position.

Typically the final filters should last 6 months to 15 months, depending upon the cleanliness of the application, the frequency of prefilter changes, and if the unit cleanup cycle is operated properly. The filter gauge will ensure the final filters have reached their full life, and are not changed prematurely. Please contact EVAPCO at 507-446-8005 for availability of filters.

Use the following procedure to change the HEPA filters.

- 1) Stop the fan motor and lockout using disconnect switch.
- 2) Remove the fully loaded final filters. (NOTE: Maintenance personnel may want to use protective clothing and facemasks while changing.) Be careful not to dislodge any of the particles collected in the filter.
- 3) Inspect the final filter frame gasketing and the retaining clips.
- 4) Check the caulking seal between the final filter frames. If any cracks are observed, caulk with a USDA/FDA sealant.
- 5) Install the new HEPA final filters. The pleats should be in the vertical position.
- 6) Clean and sanitize the final filter section.
- 7) Start the fan motor.
- 8) Make note in the maintenance schedule for the unit that the final filters have been changed.
- 9) Check filter gauge for proper operation. Recalibrate if necessary.

The HEPA filters are installed using the following procedure:

- Carefully open the box. Touch only the frame of the filter, never the white media.
- Slide in the filter into the frame, centering on the filter frame.
- Install four spring bolts to a compression of approximately 30-



50%.

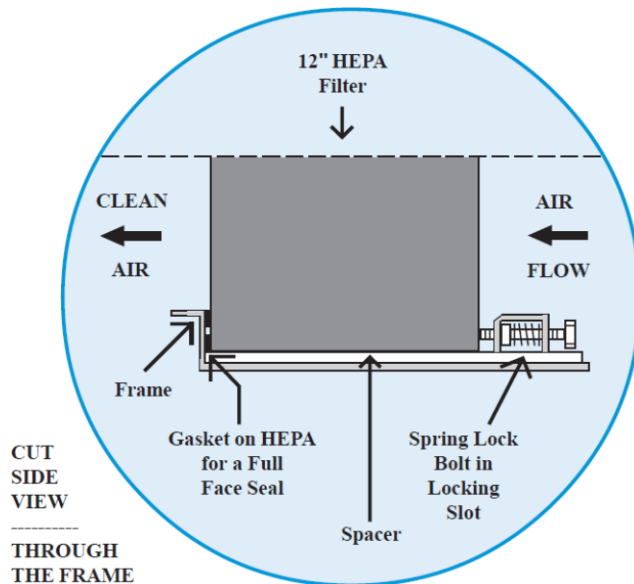

Some applications will have a three filter system, a pre, an intermediate and a final filter. The pre and intermediate filters are held in the same filter frame at the inlet of the unit using a special "P" clip. The intermediate filter "pushes through" the frame and the pre filters sits in front. The following shows the installation of the "P" clip.

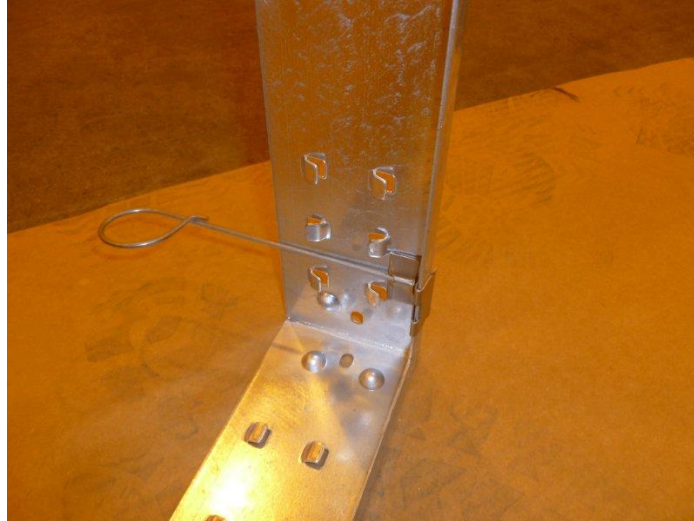

Blower, Motor and Drive Assembly:

- 1) Every 6 months the fastening bolts for the blower, motor and drive should be checked for tightness. Also, check the bearing set screws and the blower hub set screws. Check alignment of the sheaves.
- 2) A periodic maintenance schedule should be set up for checking the belts. At minimum, the belts should be checked every 6 to 9 months for wear and proper tightness and alignment.
- 3) The blower bearings should be lubricated per the lubrication instructions and schedule in the service manual.
- 4) Motors that do not have re-grease capability are factory lubricated for the normal life of the bearings. For motors with re-grease capability, they should be lubricated at these intervals:

Motor Horsepower	Rated Speed (RPM)			
	3600	1800	1200	900
2	5500	12000	18000	22000
10	3600	9500	15000	18000
40	2200	7400	12000	15000
50 and above	2200	3500	7400	10500

Baldor motors should normally be greased with Exxon Mobil Polyrex EM grease and U.S. motors either a Chevron SRI#2 or a Shell Dolium R.

Greasing procedure:

Clean the grease fitting (or the area around the hole, if equipped with slotted grease screws. If motor has a purge plug, remove it. Apply grease gun fitting. Too much grease or injecting grease too quickly can cause premature bearing failure. Slowly apply the recommended amount of grease, taking 1 minute or more to apply. Operate motor for 20 minutes, then reinstall purge plug if previously removed. Caution: Mixing dissimilar grease is not recommended.

Amount of Grease to Add

Motor Horsepower	Amount of Grease to Add	
	Weight in	Volume in
	Ounces	Teaspoons
2	0.3	2.0
10	0.61	3.9
40	0.81	5.2
50 and above	2.12	13.4

- 5) If the unit is supplied with spring isolation, check spring bolts/nuts for tightness. Also, check the flexible duct for wear.

Electrical Connections:

The control system for the unit should be checked at least twice a year for proper operation of the system. Also check all terminals to ensure they are tight. It is suggested that the units be checked in the fall, prior to the heating season and in the spring, prior to the summer cooling season. Make sure that all settings are per the operation manual.

Smoke Detector (Optional Feature)

IMPORTANT: The smoke detector must be tested and maintained regularly following NFPA 72 requirements. The detector should be cleaned and tested at least once a year. Detailed information on maintenance and service is contained within the service manual for this unit.

WARNING: WITHOUT PROPER SERVICE AND MAINTENANCE, THE SMOKE DETECTOR COULD INITIATE FALSE ALARMS OR FAIL TO FUNCTION PROPERLY IN THE CASE OF A FIRE. STRICT SERVICE AND MAINTENANCE SCHEDULES MUST BE FOLLOWED AND COMPLETE SERVICE RECORDS KEPT.

Ammonia Detector (Optional Feature)

For proper operation it is essential that the test and calibration schedule be adhered to. The supplier recommends the following maintenance schedule.

- 1) Response test once per month. Expose sensor to ammonia/water solution to verify proper sensor response and alarm functions. Test more frequently in highly critical applications.

- 2) Calibration should be performed with certified calibration gas every six months. All tests and calibrations must be logged. **Note – the sensor must have a 12 hour warm up before it can be calibrated.**

Sensor Life: These electrochemical cells are extremely reliable, but several things can cause the cell chemicals to become depleted including:

- 1) A period of time.
- 2) Exposure to high temperatures.
- 3) Exposure to varying concentrations of the target gas.
- 4) Exposure to high moisture for extended periods without proper sensor enclosure

When the cell becomes depleted, the unit will give no indication of failure other than that the sensor will not respond. For this reason it is **absolutely essential that these units be exercised with a gas sample on a regular and timely basis.**

Typical sensor life in a refrigerated area will be two to three years. Typical life in a non-refrigerated area will be one to two years. Exposure to high levels of ammonia will shorten these times. In addition to timely response checks, a preventative maintenance program of periodic cell replacement should be implemented.

When the cell becomes depleted, a replacement cell can be obtained from Evapco, 507-446-8005. Simply unplug the ribbon cable from the transmitter, pull the old cell from the spring clip, discard the old cell and replace it with a new one.

The sensor should be calibrated after a 12 hour warm-up period.

WARNING: WITHOUT PROPER SERVICE AND MAINTENANCE, THE AMMONIA DETECTOR COULD INITIATE FALSE ALARMS OR FAIL TO FUNCTION PROPERLY IN THE CASE OF AN AMMONIA LEAK. STRICT SERVICE AND MAINTENANCE SCHEDULES MUST BE FOLLOWED AND COMPLETE SERVICE RECORDS KEPT.

ESS UVC Lights (Optional feature)

- 1) **CAUTION! NEVER EXPOSE EYES OR SKIN TO UVC LIGHT. ALWAYS TURN POWER OFF, OR WEAR GLOVES, FACE SHIELDS AND COVER ANY EXPOSED SKIN, BEFORE SERVICING THE UNIT.**
- 2) **CAUTION! IMPROPER SERVICE AND MAINTENANCE CAN CAUSE FIRE, ELECTRICAL SHOCK OR OTHER CONDITIONS THAT MAY CAUSE PERSONAL INJURY OR PROPERTY DAMAGE.**
- 3) The bulbs should be replaced every 12 – 18 months and should need no maintenance between replacements. Carefully remove the old bulb(s) and check all wiring and connections to the bulbs. Carefully inspect the watertight assembly and replace if necessary.
- 4) Test all circuits. Leave the unit, close the access door, and then turn the lights on. A “blue hue” will glow from the light indicating the fixture is working. **Remember – only view the lights through the service door window, or while wearing the protective gear as described above.**
- 5) Mark your preventative maintenance calendar to replace the bulbs 12-18 months from the replacement date.

- 6) Check local codes for proper disposal of the used bulbs.

Desiccant Dehumidification (Optional feature)

- 1) **CAUTION!** The desiccant wheel is constructed of a fragile composite material. **DO NOT** clean with water, chemicals, solvents, or high pressure sprays.
- 2) See the separate section in the maintenance manual for proper cleaning and maintenance of the desiccant wheel and system.

VFD Drive Systems (Optional feature)

- 1) The control panel enclosing the VFD may contain an ambient air cooling/ventilation system. This cooling system is used to control the interior control panel temperatures for the VFD. The cooling system contains a filter which must be periodically cleaned. It is recommended it be cleaned as least as often as the pre-filters in the unit and more frequently if the atmosphere around the unit is very dirty and dusty. **Failure to keep the panel cooling filter clean can cause reduced cooling air flow to the control panel. This can result in overheating of the VFD which can then cause faults and or failure of the drive and possible damage to the unit motor.**

PLC Control Systems (Optional feature)

- 1) The control panel enclosing the PLC controls may contain an ambient air cooling/ventilation system. This cooling system is used to control the interior control panel temperatures for the PLC. The cooling system contains a filter which must be periodically cleaned. It is recommended it be cleaned as least as often as the pre-filters in the unit and more frequently if the atmosphere around the unit is very dirty and dusty. **Failure to keep the panel cooling filter clean can cause reduced cooling air flow to the control panel. This can result in overheating of the PLC which can then cause faults and or failure of the control system.**

Unit Motor Removal Rail (option):

Some units include motor removal rail/trolley system to facilitate easier and safer removal of the unit motor. Please refer to the trolley installation instructions for proper mounting of the trolley. Prior to every use, make sure the fasteners and hardware are tight and aligned. Do not "swing" the motor when on the trolley

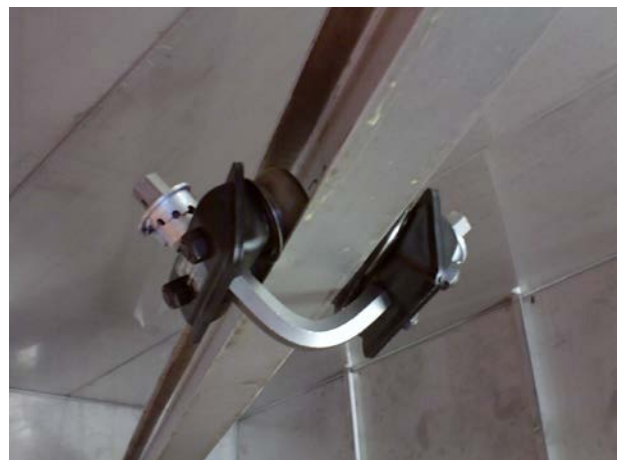
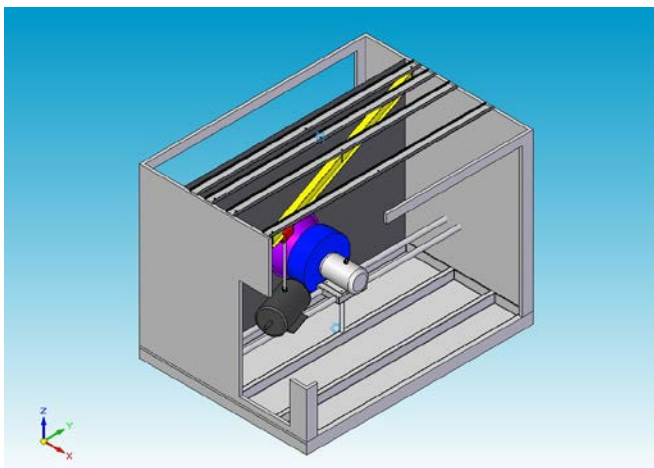

since this may stress the beam or trolley and cause an unsafe condition. Check trolley before each use and at regular intervals per the O&M manual.

Unit Roof Fall Protection Anchor(s) (option):

As an option, CPA units can be supplied with roof mounted fall protection anchor(s). The system includes a heavy backing plate, installed at the factory, with an anchor fastened to the heavy plate.



WARNING – this anchor is part of a personal fall arrest or fall restraint system. The instructions in this document and the information in the O&M manual must be read and understood before using the anchor. Alterations or misuse of the anchor or failure to follow instructions may result in serious injury or death.

The end user or contractor using the anchor must use OSHA approved full body harness and lifelines and selected for the application. Do not hang, lift or support tools or equipment from the anchor, or attach guy lines to the anchor.

It is the responsibility of the users to assure they are familiar with the instructions, trained in the correct care and use of, and are aware of the operating characteristics, application limitations, and consequences of improper use of the anchor.

The anchor is designed for use by one person with a combined weight (clothing, tools, etc.) of not more than 310 lbs (141 kg). Only one person shall be attached to the anchor at any one time.

The anchor should be inspected before each use and, additionally, by a competent person other than the user at intervals of no more than one year. Follow the inspection procedures outlined in the O&M manual. Results of the Competent Person inspection should be recorded in the maintenance log.

The anchor is not repairable. If the anchor is subject to a fall force or inspection reveals an unsafe or defective condition, remove the anchor from service

Indirect Fired Heating Section:

The heat exchanger and stack should be inspected before the start of each heating season. Make sure the stack is intact and has not deteriorated or the roof cap leaking. Check the drain to ensure it is open and free flowing. Check the heat exchanger for cracks or other deterioration.

Completely check the gas train for leaks. Check the complete control system and all safeties for proper operation.

CAUTION! INDIRECT FIRED HEAT CHANGERS AND FLUE VENT STACKS ARE SUPPLIED WITH CONDENSATE DRAIN CONNECTIONS PIPED TO THE OUTSIDE OF THE UNIT. THIS CONDENSATE CAN BE CORROSIVE AND EXTREME CARE SHOULD BE EXCERCISED WHEN SELECTING A LOCATION FOR DISCHARGE OF THE CONDENSATE. CONDENSATE SHOULD NOT BE DISCHARGED ON TO A ROOF. FOLLOW ALL STATE AND LOCAL CODES.

SEMI-ANNUALLY CHECK THE DRAINS AND DRAIN PIPING/TRAPS TO ENSURE THEY ARE FREE FLOWING. FAILURE TO EFFECTIVLY DRAIN CONDENSATE FORMED IN THE HEAT EXCHANGER CAN RESULT IN PREMATURE CATASTROPHIC FAILURE OF THE HEAT EXCHANGER.

Miscellaneous Items:

- 1) Check the operation of the dampers every time the electrical controls are checked. Make sure that all of the linkage operates freely and the dampers function correctly.
- 2) Check the seal between the sections on the units. Make sure the section split seals remain water and air tight.
- 3) Check all drain traps to make sure that they are not plugged and have an adequate water seal. Make sure that the other drain pans do not have standing water in them.
- 4) Check all door gasketing yearly to make sure there is an airtight seal.
- 5) If the unit is supplied with a control panel cooling system, clean or replace the filter regularly.

12-4-15

**EVAPCO, Inc. 215 1st Street NE, P.O. Box 88 Medford, MN 55049
Phone: (507) 446-8005 Fax: (507) 446-8239**